

## Problem 18

The system is composed of a linear system to be stabilized, a non-linear actuator and some fast stable unmodeled dynamics of the actuator. The general detailed problem description is singled out.

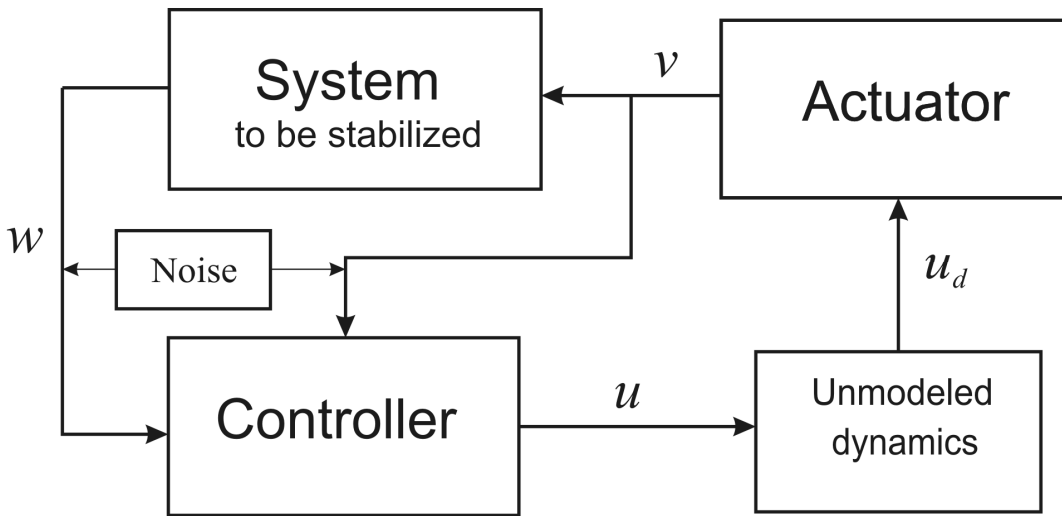

1. The system to be stabilized:  $\dot{w} = Aw + Bv$ ,  $w \in \mathbb{R}^3, v \in \mathbb{R}$  is the input,

$$A = \begin{pmatrix} 0.5 & -1 & 1 \\ -1 & 0 & -1 \\ 1 & 0 & 1 \end{pmatrix}, \quad B = \begin{pmatrix} 1 \\ 0 \\ 1 \end{pmatrix}.$$

2. The actuator output is defined as  $v = x_1$ , where the actuator equations are

$$\dot{x}_1 = \cos 0.5t - 2 \cos t + 2 x_2,$$

$$\dot{x}_2 = a(x_1, x_2, x_3, t) + (3 + \cos x_3) u_d,$$

$$\dot{x}_3 = \sin(2x_1 - 2x_2 + x_3 - 11t) - x_3 + 0.2 u_d.$$

3. The “unmodeled” (singular) dynamics (actually a part of the actuator) is for the simulation presented by the equation

$$\ddot{u}_d = -3\epsilon^{-1}\ddot{u}_d - 3\epsilon^{-2}\dot{u}_d - 4\epsilon^{-3}(u_d - u).$$

4.  $a(x, t)$  represents the system uncertainty. **For a single student (I) and for a pair of students (II):** for both  $a = \cos(3 - x_3)$  and  $a = \cos(x_2 + x_3)$  the same controller is to provide for the exact actuator tracking of the two command signals

$$v_c(t) = 2 \sin(2.5t + 1) - \cos(1.3t), \quad (1)$$

$$v_c(t) = -2 \sin(2t) - \cos(t - 2) + 0.01 \cos 10t.$$

בהצלחה!