

## Problem 11

The system is composed of a linear system to be stabilized, a non-linear actuator and some fast stable unmodeled dynamics of the actuator. The general detailed problem description is singled out.

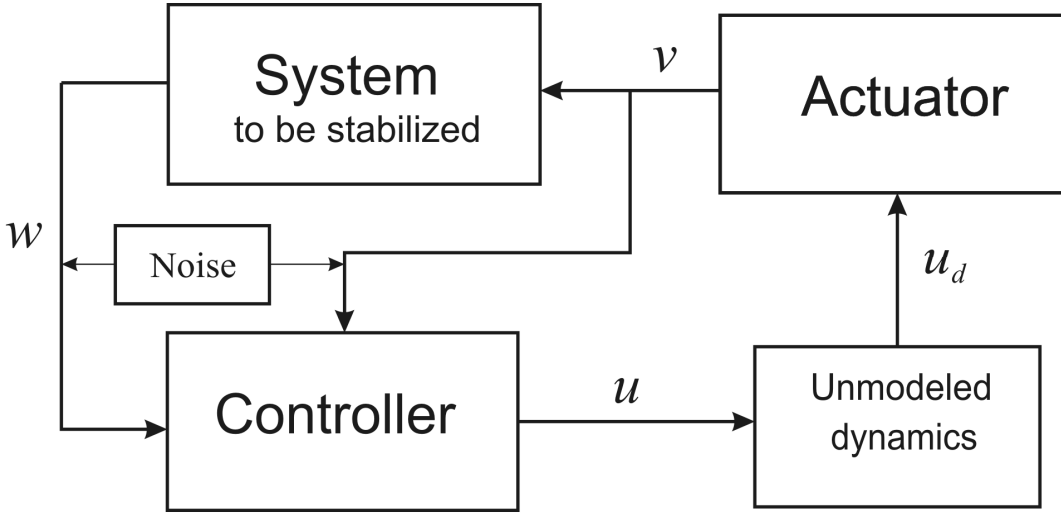

1. The system to be stabilized:  $\dot{w} = Aw + Bv$ ,  $w \in \mathbb{R}^3, v \in \mathbb{R}$  is the input,

$$A = \begin{pmatrix} 1 & 1 & 0 \\ -1 & -1 & 1 \\ 1 & 1 & 1 \end{pmatrix}, \quad B = \begin{pmatrix} 1 \\ 1 \\ 2 \end{pmatrix}.$$

2. The actuator output is defined as  $v = x_1$ , where the actuator equations are

$$\dot{x}_1 = -\sin(t + 5) - 0.5 \cos t - x_2,$$

$$\dot{x}_2 = a(x_1, x_2, x_3, t) + (2 + \cos(x_1 + x_3 + 7)) u_d,$$

$$\dot{x}_3 = \cos(x_1 + 0.5 x_3 - t) - x_3 - 0.5 u_d.$$

3. The “unmodeled” (singular) dynamics (actually a part of the actuator) is for the simulation presented by the equation

$$\ddot{u}_d = -4\varepsilon^{-1} \ddot{u}_d - 2\varepsilon^{-2} \dot{u}_d - 6\varepsilon^{-3} (u_d - u).$$

4.  $a(x, t)$  represents the system uncertainty. **For a single student (I) and for a pair of students (II):** for both  $a = \cos(1 - 3x_3)$  and  $a = \cos(1 + 3x_3)$  the same controller is to provide for the exact actuator tracking of the two command signals

$$v_c(t) = \sin(t + 1.7) - \cos(0.4t - 5), \quad (1)$$

$$v_c(t) = -\sin(t - 10) + 0.1 \cos(5t + 8) + 0.01 \cos 10t.$$

בהצלחה!