

Problem 15

The system is composed of a linear system to be stabilized, a non-linear actuator and some fast stable unmodeled dynamics of the actuator. The general detailed problem description is singled out.

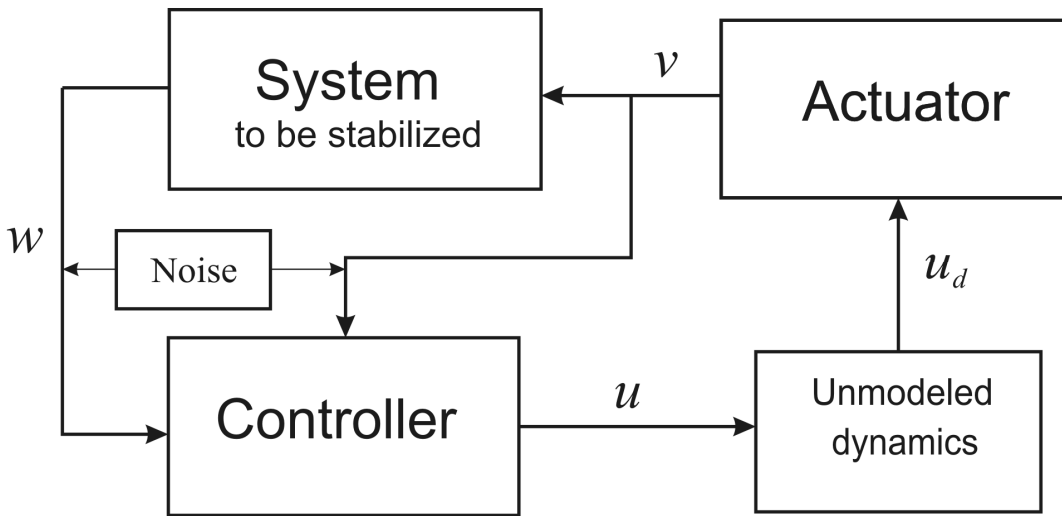

1. The system to be stabilized: $\dot{w} = Aw + Bv$, $w \in \mathbb{R}^3, v \in \mathbb{R}$ is the input,

$$A = \begin{pmatrix} 1 & -1 & -1 \\ 2 & -1 & 1 \\ 1 & 0 & 1 \end{pmatrix}, \quad B = \begin{pmatrix} 1 \\ 1 \\ 1 \end{pmatrix}.$$

2. The actuator output is defined as $v = x_1$, where the actuator equations are

$$\dot{x}_1 = -\sin(0.7t - 5) + 0.5 \cos 2t + 2x_2,$$

$$\dot{x}_2 = a(x_1, x_2, x_3, t) + (2 - \cos x_1) u_d,$$

$$\dot{x}_3 = \cos(2x_1 - x_3 + t) - 2x_3 + 0.3u_d.$$

3. The “unmodeled” (singular) dynamics (actually a part of the actuator) is for the simulation presented by the equation

$$\ddot{u}_d = -\varepsilon^{-1} \ddot{u}_d - 3\varepsilon^{-2} \dot{u}_d - 2\varepsilon^{-3} (u_d - u).$$

4. $a(x, t)$ represents the system uncertainty. **For a single student (I) and for a pair of students (II):** for both $a = \cos(1 - 2x_3)$ and $a = \cos(1 + 2x_3)$ the same controller is to provide for the exact actuator tracking of the two command signals

$$v_c(t) = \sin(1.3t + 1) - 0.8 \cos(0.9t - 5), \quad (1)$$

$$v_c(t) = -2 \sin(2t) + \cos(t - 1) + 0.01 \cos 20t.$$

בהצלחה!