

Problem 14

The system is composed of a linear system to be stabilized, a non-linear actuator and some fast stable unmodeled dynamics of the actuator. The general detailed problem description is singled out.

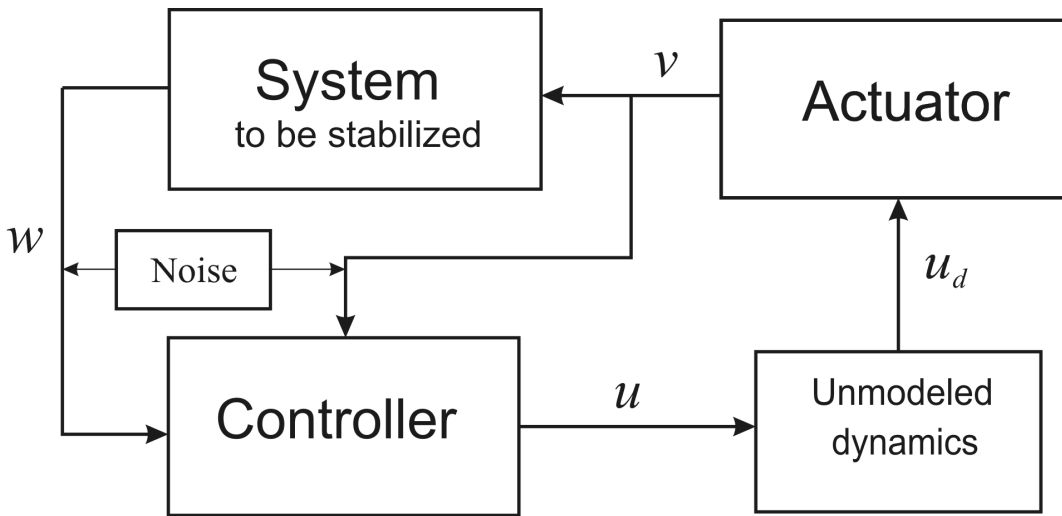

1. The system to be stabilized: $\dot{w} = Aw + Bv$, $w \in \mathbb{R}^3, v \in \mathbb{R}$ is the input,

$$A = \begin{pmatrix} 1 & 1 & -1 \\ 2 & -1 & 1 \\ 1 & 0 & 1 \end{pmatrix}, \quad B = \begin{pmatrix} 1 \\ 1 \\ 1 \end{pmatrix}.$$

2. The actuator output is defined as $v = x_1$, where the actuator equations are

$$\begin{aligned} \dot{x}_1 &= -\sin(0.8t + 5) - 0.5 \cos t + 2x_2, \\ \dot{x}_2 &= a(x_1, x_2, x_3, t) + (1 - 0.5 \cos x_1) u_d, \\ \dot{x}_3 &= \cos(x_1 - x_3 - t) - 2x_3 + 0.3u_d. \end{aligned}$$

3. The “unmodeled” (singular) dynamics (actually a part of the actuator) is for the simulation presented by the equation

$$\ddot{u}_d = -3\varepsilon^{-1} \ddot{u}_d - \varepsilon^{-2} \dot{u}_d - 2\varepsilon^{-3} (u_d - u).$$

4. $a(x, t)$ represents the system uncertainty. **For a single student (I) and for a pair of students (II):** for both $a = \cos(1 - 3x_3)$ and $a = \cos(1 + 3x_3)$ the same controller is to provide for the exact actuator tracking of the two command signals

$$\begin{aligned} v_c(t) &= \sin(1.8t + 1) - 0.8 \cos(t - 5), \\ v_c(t) &= -\sin(1.5t) + 0.5 \cos(t - 1) + 0.01 \cos 20t. \end{aligned} \tag{1}$$

בהצלחה!