

Geometry and Arithmetic in the Medieval Traditions of Euclid's *Elements*: a View from Book II

Leo Corry – Tel Aviv University

*Dedicated to my dear friend
Sabetai Unguru on his 82th birthday*

Contents

1. Abstract	1
2. Introduction	2
3. Euclid's <i>Elements</i> - Book II and Geometric Algebra	7
3.1. <i>Elements</i> Book II – An Overview	7
3.2. Geometric Algebra – An Overview	14
3.3. Visible and Invisible Figures	18
4. Book II in Late Antiquity and in Islam Mathematics	22
4.1. Heron's Commentary of the <i>Elements</i>	22
4.2. Al-Khwārizmī and Abū Kāmil	27
4.3. Thābit ibn Qurra	35
4.4. Al-Nayrīzī	38
5. Book II in the Early Latin Medieval Translations of the <i>Elements</i>	41
6. Book II in Other Medieval Texts	48
6.1. Abraham Bar-Ḥiyya	48
6.2. Liber Mahameleth	62
6.3. Fibonacci	66
6.4. Jordanus Nemorarius	77
6.5. Campanus	86
6.6. Gersonides	92
6.7. Barlaam	100
7. Concluding Remarks	104
8. Acknowledgements	106
9. References	106

1. Abstract

This article explores the changing relationships between geometric and arithmetic ideas in medieval Europe mathematics, as reflected via the propositions of Book II of Euclid's *Elements*. Of particular interest is the way in which some of medieval treatises organically incorporated into the body of arithmetic some of the main results of Book II, and how, subsequently, and particularly in the Campanus version of the *Elements*, these arithmetic versions of results, which were originally conceived in the context of geometry, were reincorporated into the arithmetic books of the Euclidean treatise. Thus, while most of the Latin versions of the *Elements* had duly preserved the purely geometric spirit of Euclid's original, the specific text that played the most prominent role in the initial passage of the *Elements* from manuscript to print – i.e., Campanus' version – followed a different approach. On the one hand, Book II itself continued to appear there as a purely geometric text. On the other hand, the first ten results of Book II could now be seen also as *possibly translatable* into arithmetic, and in many cases even as *inseparably associated* with their arithmetic representation.

2. Introduction

Book II of Euclid's *Elements* raises interesting historical questions concerning its intended aims and significance. The book has been accorded a rather singular role in the recent historiography of Greek mathematics, particularly in the context of the so-called “geometric algebra” interpretation. According to this interpretation, Greek geometry as epitomized in the works of Euclid and Apollonius is – at least in its fundamental aspects – nothing but algebra in disguise.¹

In 1975 Sabetai Unguru published an article in which he emphatically criticized the geometric algebra interpretation. He claimed that Greek geometry is just that, geometry, and that any algebraic rendering thereof is anachronistic and historically misguided (Unguru 1975). Unguru, to be sure, was elaborating on a thesis previously put forward by Jacob Klein in his classic *Greek Mathematical Thought and the Origin of Algebra* (Klein 1968 [1934-36]), about a great divide between ancient and modern mathematics around the basic conceptions of number and of geometry. Unguru's article ignited a harsh controversy with several well-known mathematicians with an interest in history, such as Bartel L. van der Waerden (1903-1996), Hans Freudenthal (1905-1990) and André Weil (1906-1998) (van der Waerden 1976, Freudenthal 1977, Weil 1978). In spite of the bitter debate, however, the controversy quickly receded and Unguru's view became essentially a mainstream interpretation accepted by most historians. Unguru's criticism has since stood (at least tacitly) in the background of most of the serious historical research in the field.

Still, once we have acknowledged the misleading way in which the geometric algebra

¹ Beginning in the late nineteenth century, this view was promoted by prominent scholars such as Paul Tannery (1843–1904), Hieronymus Georg Zeuthen (1839-1930), Sir Thomas Little Heath (1861–1940), and Otto Neugebauer (1899–1990). Book II became a pivotal focus in the elaboration of the details of this historiographical perspective.

interpretation explains the mathematics of the past by using ideas that were not present in Euclid's or in Apollonius's time, some additional, interesting questions arise that call for further historical research. Thus for instance, as an alternative to geometric algebra, one may ask for a coherent, *purely geometric* explanation of the aims and scope of the ideas originally developed in the Greek mathematical texts. This question has been illuminatingly addressed, for instance, by Ken Saito concerning Book II and its impact on Apollonius's *Conics* (Saito 2004 [1985]), and I will return to it below.

A different kind of question that arises when one rejects the geometric algebra interpretation of Greek geometry concerns the origins and historical development of this very historiographical view. Thus, it is well known that beginning in late antiquity and then throughout history, in editions or commentaries of the *Elements*, as well as in other books dealing with related topics, classic geometrical results were variously presented in partial or full arithmetic-algebraic renderings. It is evident that this mathematical transformation later affected some of the retrospective historical interpretations of what Euclid had in mind when originally writing his own text. But what was the *precise interplay* between the changes at these two levels, mathematical and historiographical, in the different historical periods? A full exploration of this *longue durée* question, starting from Euclid and all the way down to the historians who vigorously pursued the geometric algebra interpretation in the late nineteenth-century, is a heavy scholarly task. In the present article I intend to address a partial aspect of it, by focusing on the ways in which mathematicians in Medieval Europe presented the propositions of Book II in the most widely circulated Euclidean versions, as well as in other texts that incorporated some of the propositions of that book. I suggest exploring the extent to which arithmetic and proto-algebraic ideas were absorbed in those texts and hence modified the original

Euclidean formulation, and (to a lesser degree) whether and how these changes affected the historical conception of Euclid.

Before entering the discussion, however, it is important to stress from the outset that I deliberately ignore the debate about the adequacy of using the term “algebra” in this or that historical context, and consider it a matter of taste. As I have explained elsewhere, the question about the “essence of algebra” as an ahistorical category seems to me an ill-posed and uninteresting one (Corry 2004, 397). Thus, I am not interested in adjudicating the question whether or not certain specific ideas found in Heron or in al-Khwārizmī count as “algebra” according to some predetermined, clearly agreed criteria. Rather, I want to identify those mathematical ideas *not* originally found in Euclid’s text and that were gradually incorporated into interpretations of it or even into the edited versions of the text itself. In this article, just for convenience, I refer to some of those ideas using the general umbrella terms of “arithmetic” or “algebra”, in their more or less agreed sense, and without thereby aiming at an essentialist perspective on these concepts. This in itself should not give rise to any debate or confusion.

The core of the article is preceded by two relatively lengthy introductory sections. In §3, I discuss some of the propositions of Book II and their proofs as they appear in the original Euclidean text known to us nowadays.² I devote particular attention to II.5 which in most of the examples analyzed here serves well as a focal point that

² The issue of the adequate use of direct and indirect sources in order to establish an authoritative version of the Euclidean text is a significant historiographical question still under debate nowadays. See (Rommevaux, Djebbar and Vitrac 2001). I do not deal at all with this issue here and I simply follow the widely accepted English version, (Heath 1956 [1908]).

illustrates the issues considered.³ I thus present the typical (anachronistic) algebraic interpretation of this result and I discuss its shortcomings. In §4, I present some versions of the same propositions, as were introduced in texts of late antiquity and of Islam mathematics. This section is not intended as an exhaustive survey of such texts, but rather as a presentation of versions that were available to the medieval translators and interpreters of Euclid and that in many cases provided the source for contemporary renderings of propositions of Book II. These two sections, §§3-4, are intended as a consistent synthesis which, while strongly relying on the existing scholarship, stresses some less noticed aspects and thus hopefully helps making a fresh reading of the history of Book II in its early phases.

After these introductory sections I move to the core part of the article, where I analyze propositions from Book II as they appear in medieval versions of the *Elements* (in §5) and in other contemporary books that incorporated such ideas (in §6). The period discussed comprises the first Latin translations of the Euclidean text in the 12th century, and it also includes additional texts that circulated in Europe in manuscript versions before the first printed version of the *Elements* in 1482. Thus, I discuss the *Liber Mahameleth*, as well as additional texts by Abraham Bar-Hiyya, Fibonacci, Jordanus Nemorarius, Gersonides, and Barlaam. These works present us with a rather heterogeneous variety of approaches, within which propositions from Book II were handled with the help of both geometric and arithmetic ideas. Some of these treatises organically incorporated into the body of arithmetic the main results of Book II. Subsequently, and particularly in the Campanus version of the *Elements*, existing arithmetic versions of results from Book II were reincorporated into the arithmetic

³ Proposition II.5 has also been used as focal point in other accounts about Greek mathematics or about changing views on geometry through history see e.g., Neal 2002, 123 ff.; Netz 1999, 9-11; Vitrac and Caveing 1990, 370-372.

books the Euclidean treatise, Books VII-IX. As a consequence, while most of the Latin versions of the *Elements* had duly preserved the purely geometric spirit of Euclid's original, the specific text that played the most prominent role in the initial passage of the *Elements* from manuscript to print – i.e., Campanus' version – followed a different approach. On the one hand, Book II itself continued to appear as a purely geometric text. On the other hand, the first ten results of Book II could now be seen also as *possibly translatable* into arithmetic, and in many cases even as *inseparably associated* with their arithmetic representation. Hence, when symbolic techniques of algebra started to take center stage in renaissance mathematics in Europe, the algebraic interpretation of results in Book II could become a natural, additional step to be followed.

In the discussion below, as already indicated, proposition II.5 provides a significant focal point for the analysis pursued. Nevertheless, this focus allows only a limited view on the broader issue at stake. On closer analysis, one realizes that another issue of crucial importance in this story is the way in which distributivity of the product over addition was handled in the various medieval texts that I study here. In consideration with the already substantial length of this article, I have pursued that issue in a separate essay, soon to be published, and to which I refer in the relevant places as [LC2].

Another remark related to the length of my article is the following: since, of necessity, the text below includes many detailed proofs that differ from each other in specific important points, yet in subtle and perhaps non-dramatic manners, I have followed the convention of writing some paragraphs using a different font. This is meant as an indication to the reader that these paragraphs comprise purely technical descriptions of proofs, and that they are intended as evidence in support of the general claims

made in the corresponding sections. The paragraphs may be read with due technical attention, or they may be skipped at least temporarily without thereby missing the general line of argumentation.

3. *Euclid's Elements - Book II and Geometric Algebra*

Book II of the *Elements* is a brief collection of only fourteen propositions. The first ten can be seen as providing relatively simple tools to be used as auxiliary lemmas in specific, more complex constructions later on. Euclid applied the results in the proofs of the last four propositions of Book II (II.11, for instance, teaches how to obtain the mean and extreme section of any given segment), as well as in other books of the *Elements*. Later on, they can be found in important places such as Apollonius *Conica*. Each of the first ten propositions was proved by Euclid directly with the help of results taken from Book I, and without relying on any other result from Book II. It is easy to see, however, that once II.1 is proved on the basis of I.34, the other nine propositions could be proved with its help. This is not what Euclid did in his text, but as we shall see, the possibility was acknowledged from very early on.

3.1. *Elements Book II – An Overview*

Since I will be referring throughout the article to some propositions in Book II and to their proofs, I present now propositions II.1-II.6 and II.9-II.10, with varying degrees of detail (according to what is needed in the discussion below). I also add some general comments at the end of the presentation (all the quotations are taken from

(Heath 1956 [1908]):⁴

II.1: If there are two straight lines, and one of them is cut into any number of segments whatever, then the rectangle contained by the two straight lines equals the sum of the rectangles contained by the uncut straight line and each of the segments.

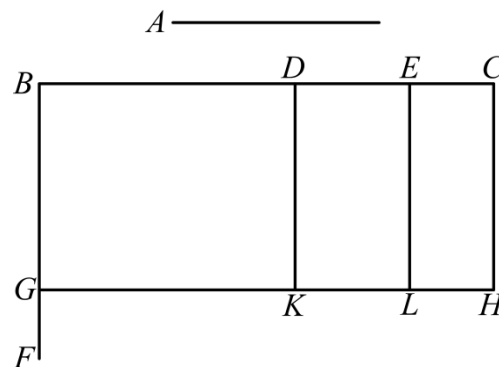

Figure 1

Here A is the first given straight line, and BC is the second one. BC is divided into three parts: BD , DE , EC (this is meant to indicate that BC is cut into “any number of segments whatever”). The construction is straightforward, setting BG equal to A , and perpendicular to BC , and then drawing DK , EL , and CH parallel to BG . All that is necessary to complete the proof is that DK be equal A , and this follows from the fact that BK is by construction a rectangle, and hence (by I.34) DK , being opposite to BG , equals BG . For the same reason also EL and CH are equal to BG , and all the three parallelograms can be taken together to form the parallelogram BH .

II.2: If a straight line is cut at random, then the sum of the rectangles

⁴ Recent scholarship has devoted increased attention to the ways in which diagrams appearing in critical editions of the *Elements* differ from those in extant manuscripts. See, e.g. (Saito & Sidoli 2012). Although considerations of this kind may be relevant to our analysis here, in this article I will refer only to diagrams as they appear in the available critical editions.

contained by the whole and each of the segments equals the square on the whole.

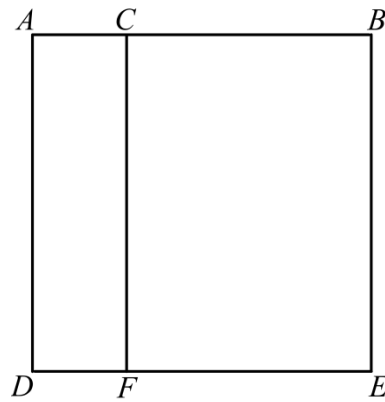

Figure 2

II.3: If a straight line is cut at random, then the rectangle contained by the whole and one of the segments equals the sum of the rectangle contained by the segments and the square on the aforesaid segment.

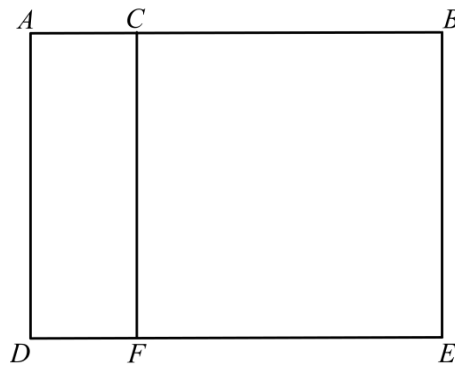

Figure 3

II.4: If a line is cut at random, then the square on the whole is equal to the squares on the segments and twice the rectangle contained by the segments.

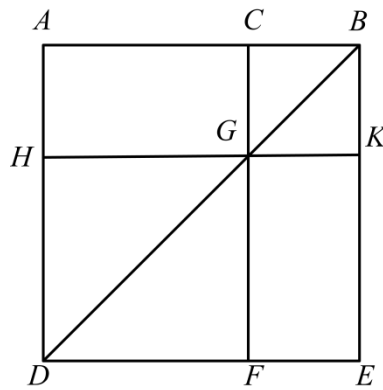

Figure 4

II.5: If a straight line be cut into equal and unequal segments, the rectangle contained by the unequal segments of the whole together with the square on the straight line between the points of section is equal to the square on the half.

The straight line AB is cut into equal segments at C and into unequal segments at D . The proposition says that the rectangle on AD, DB together with the square on CD is equal to the square on CB . The diagram is built by taking $AK = AD, BF = CB$.

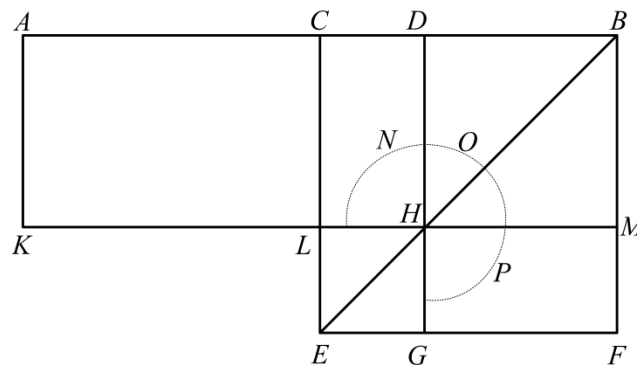

Figure 5

In the proof Euclid makes use of a gnomon, NOP , which is the figure obtained when joining the rectangles HF, CH , together with the square DM . Euclid's proof can be visualized as follows:

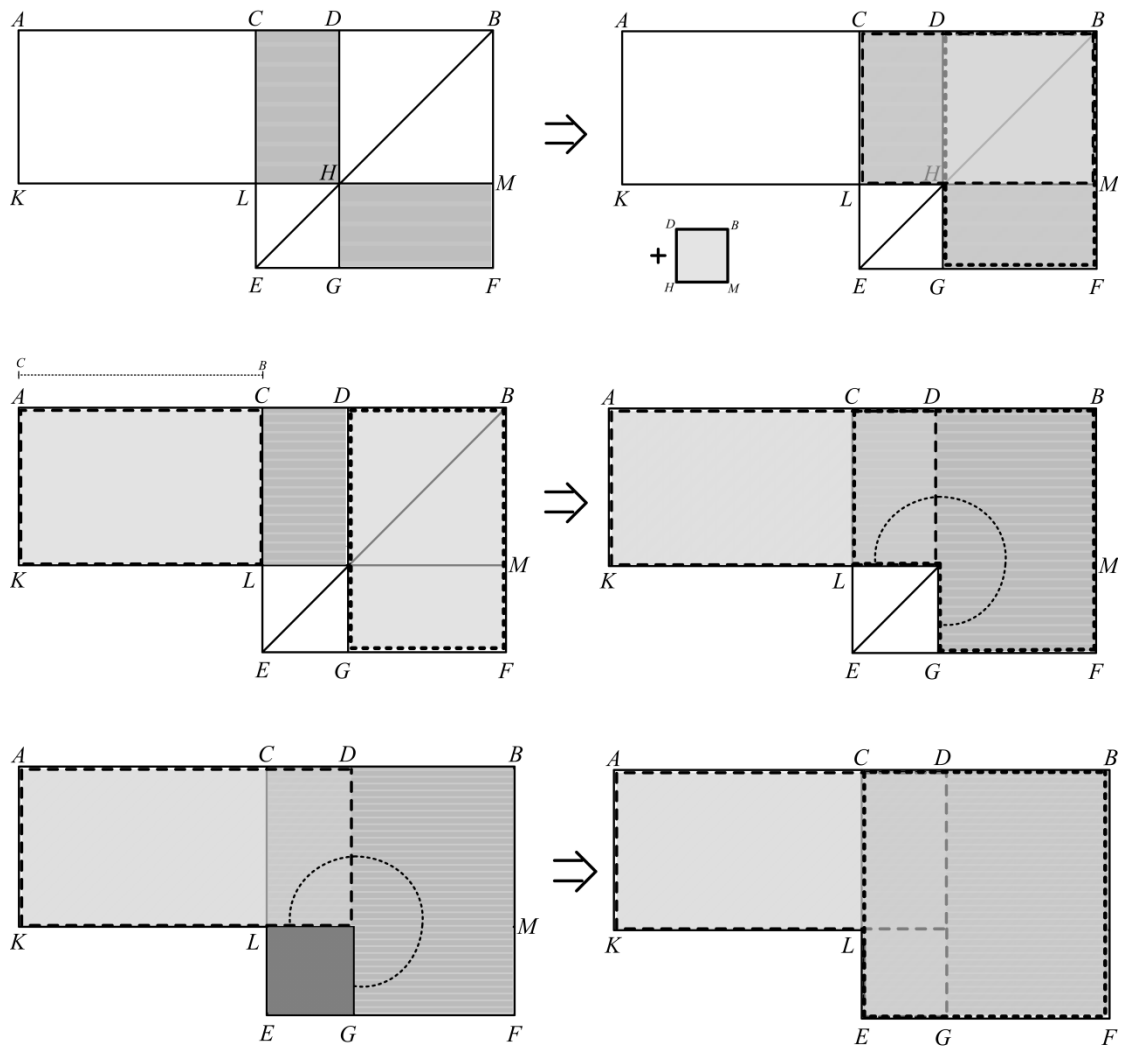

Figure 6

Schematically, Euclid's argument can be summarized as follows [Sq(CD) means

“the square of CD ” and $R(CD, DH)$ means the rectangle built on CD, DH]:

- (a.1) By I.43: $R(CD, DH) = R(HM, MF)$, and hence $R(CB, BM) = R(DB, BF)$
- (a.2) But $R(CB, BM) = R(AC, AK)$ and hence $R(AC, AK) = R(DB, BF)$
- (a.3) Hence $R(AC, AK) + R(CD, DH) = R(DB, BF) + R(CD, DH)$, or,
- (a.4) $R(AD, AK) = \text{Gnomon } NOP$ or $R(AD, DB) = \text{Gnomon } NOP$
- (a.5) Hence $R(AD, DB) + \text{Sq}(LH) = \text{Gnomon } NOP + \text{Sq}(LH)$ or,
- (a.6) $R(AD, DB) + \text{Sq}(CD) = \text{Sq}(CB)$ Q.E.D.

II.6: If a straight line is bisected and a straight line is added to it in a straight line, then the rectangle contained by the whole with the added straight line and the added straight line together with the square on the half equals the square on the straight line made up of the half and the added straight line.

The segment AB is bisected at C , and a segment BD is added to it in a straight line. The proposition says that the rectangle AD, DB together with the square on CB equals the square on CD . The diagram is built by taking $AK = BD, DF = CD$.

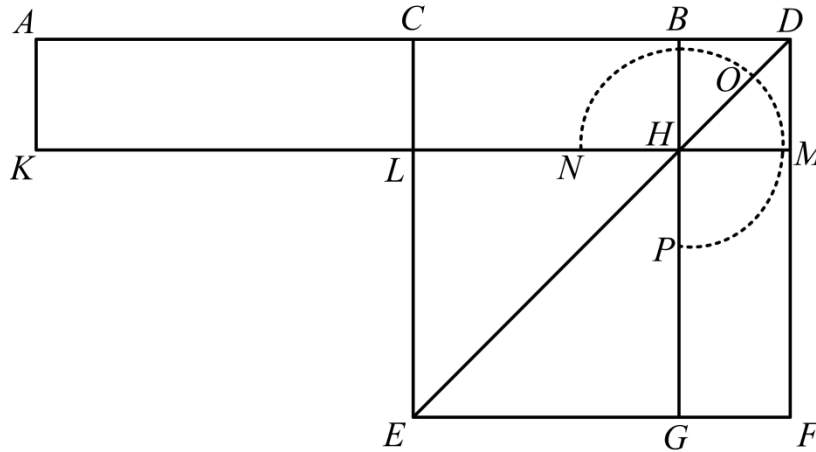

Figure 7

Like in II.5, also in this case, a key step in Euclid’s proof is based on the use of a gnomon, NOP , and of II.43 in order to assert that $CH = HF$.

II.9: If a straight line be cut into equal and unequal segments, the squares on the unequal segments of the whole are double of the square on the half and of the square on the straight line between the points of the section.

The straight line AB is cut into equal segments at C and into unequal segments at D . the proposition says that the squares on AD, DB are double of the squares on AC, CD .

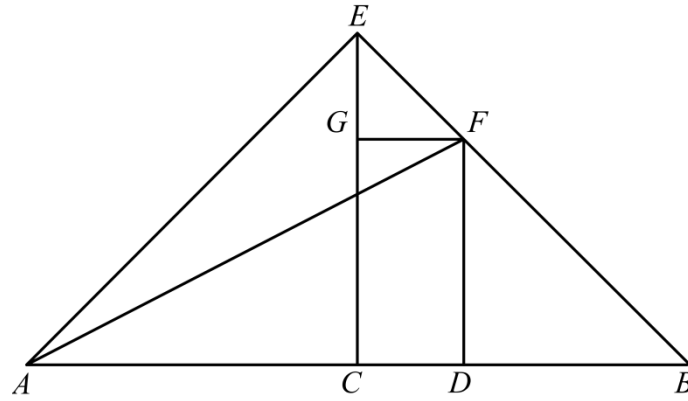

Figure 8

The proof refers to the diagram above where $GF = CD$, $EC = AC = CB$, and wherein the angles AEB , ECA , ECB are easily shown to be right angles. The Pythagorean theorem (I.47) is thus applied several times, as follows:

- (b.1) By construction and by I.47: $Sq(AE) = 2 \cdot Sq(AC)$
- (b.2) By construction and by I.47: $Sq(EF) = 2 \cdot Sq(GF) = 2 \cdot Sq(CD)$
- (b.3) Hence: $Sq(AE) + Sq(EF) = 2 \cdot Sq(AC) + 2 \cdot Sq(CD)$
- (b.4) But by I.47: $Sq(AF) = Sq(AE) + Sq(EF)$
- (b.5) Hence [from (b.3) and (b.4)]: $Sq(AF) = 2 \cdot Sq(AC) + 2 \cdot Sq(CD)$
- (b.6) But by I.47: $Sq(AF) = Sq(AD) + Sq(DF) = Sq(AD) + Sq(DB)$
- (b.7) From (b.5) and (b.6): $Sq(AD) + Sq(DB) = 2 \cdot Sq(AC) + 2 \cdot Sq(CD)$ **Q.E.D.**

II.10: If a straight line is bisected, and a straight line is added to it in a straight line, then the square on the whole with the added straight line and the square on the added straight line both together are double the sum of the square on the half and the square described on the straight line made up of the half and the added straight line as on one straight line.

The segment AB is bisected at C , and a segment BD is added to it in a straight line.

The proposition says that the squares on AD , DB are double of the squares on AC , CD .

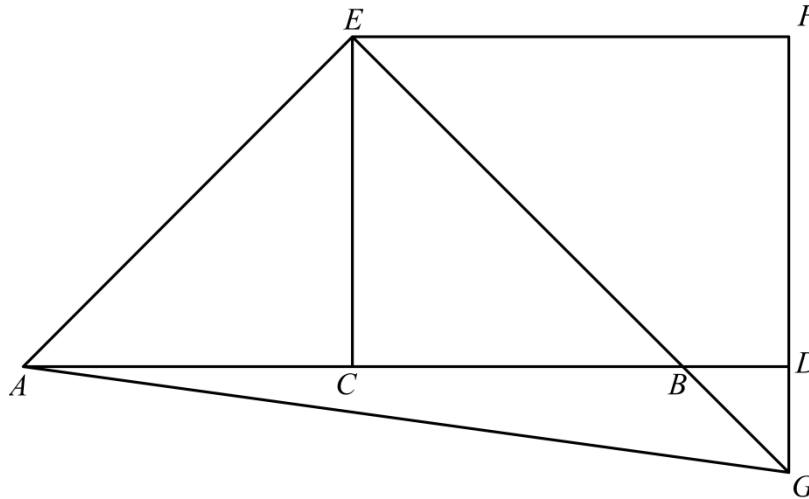

Figure 9

3.2. Geometric Algebra – An Overview

Even a superficial glance at II.1 immediately indicates why the algebraic interpretation readily suggests itself to a modern reader, who would identify here a particular case of the distributive property of multiplication over addition seen as an algebraic rule. Of course, this identification requires that we add some ideas that do not appear in the text as cited, such as equating area formation with multiplication of abstract quantities. But a reader that is willing to ignore the historical context will have no difficulty in doing so, even though what the texts displays is a *purely geometric* formulation and proof of a property of area formation.

The situation becomes somewhat more complex and interesting if we look at II.5 and II.6. In his well-known comments to these propositions, Heath gave the typical geometric algebra interpretation, by assigning algebraic symbols to segments in the diagram of II.5, as follows: $AD = a$, $BD = b$, hence $CB = (a+b)/2$ and $CD = (a-b)/2$ (Heath 1956 [1908], Vol. 1, 383). In these terms, the proposition can be interpreted as an algebraic identity, namely,

$$\left(\frac{a+b}{2}\right)^2 - \left(\frac{a-b}{2}\right)^2 = ab.$$

One interesting feature of his interpretation is that the relevant expression for the proposition changes if we call the segments differently. In particular, the two propositions, II.5-II.6, can be made to represent one and the same expression, namely, “the difference of the squares of two straight lines is equal to the rectangle contained by their sum and difference”, or $(a+b)\cdot(a-b) = a^2 - b^2$. This equivalent formulation obtains if the two lines in Figure 10 below represent the two propositions, with a and b being CB and CD , respectively, whereas AD and BD are taken as their sum and their difference respectively. Thus:

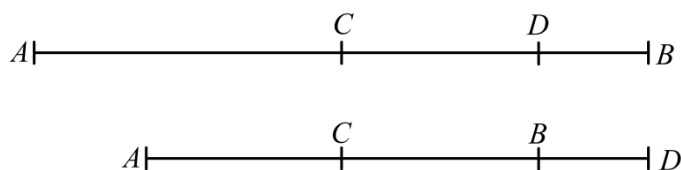

Figure 10

Moreover, the two same lines could be taken to represent a putative algebraic interpretation common to II.9-II.10: “The sum of the squares on the sum and difference of two given straight lines is equal to twice the sum of the squares on the lines” or $(a+b)^2 + (a-b)^2 = 2\cdot(a^2 + b^2)$ (Heath 1956 [1908], Vol. 1, 394). This interpretive flexibility may be seen as either an advantage or a disadvantage, depending on what viewpoint we adopt, but it certainly raises some concerns that require being clearly addressed.

Thus, if we remain close to the Euclidean text we have to admit that, particularly in the case of II.5 and II.6, both the proposition and its proof are formulated in purely geometric terms. There are no arithmetic operations involved, and surely there is no

algebraic manipulation of symbols representing the magnitudes involved. The entire deduction relies on the basic properties of the figures that arise in the initial construction or that were proved in previous theorems (which in turn were proved in purely geometric terms). Thus, for instance, the claim that “the complement CH is equal to the complement HF ” corresponds to proposition I.43 of the *Elements*. The gnomon NOP is a geometric figure built out of other figures, and similar gnomons appear in many other proofs in Greek geometry. It is clear that, while one might easily claim (albeit with little historical justification, but at least with some mathematical justification) that rectangle formation is a geometric equivalent of arithmetic multiplication, no such natural, arithmetic equivalent can be suggested for “gnomon formation”. Unguru’s criticism of the geometric algebra interpretation laid stress on this kind of interpretive difficulties concerning the meaning of the operations. It also indicated the inherent difficulty to define a clear, general arithmetic of abstract magnitudes in Greek mathematics, of which the putative algebra would be a generalization (Unguru & Rowe 1981-82; see also Mueller 1981, 50-52).

Whether or not one accepts this kind of criticism, it is pertinent to notice that when it comes to the *arithmetical* books of the *Elements*, Books VII-IX, the discussion may require some specific adaptations, since the arguments against the algebraic interpretation of geometric situations cannot simply be extended without further comments. I discuss this issue more at length in [LC2]. Nevertheless I want to stress here one point concerning the way in which numbers and operations upon them are represented in the arithmetical books of Euclid, while contrasting it with the case of the geometric books. This is a very important point for our discussion below on the medieval texts. The accompanying diagram for VII.5 is useful for our purposes here:

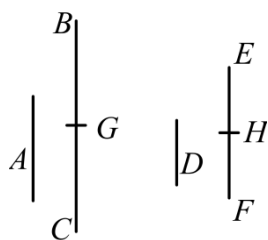

Figure 11

As in all diagrams associated with the arithmetical propositions in the *Elements*, lines represent here numbers while the operations of addition and subtraction can be represented by concatenation of lines. In this diagram, for instance, EF is the sum of EH, HF . This is not different from addition of two lines in the geometric context. When it comes to *multiplication*, however, we need to be more attentive to the differences between the two contexts. The number A , for instance, is “a part” of BC , which means that A , if added repeatedly to itself, yields BC . In the proof, Euclid simply counts and compares the “multitude” of times that one number is part of the other in the cases considered. I will be referring below to this kind of argument as “counting units”. In the Euclidean texts, such arguments appear in the context of “arithmetic proofs”, where lines appearing in diagrams are used just to represent and to label arbitrary numbers and actual constructions are never performed on them. These lines are not multiplied with each other, but they can be multiplied in the sense of repeated addition. In contrast, in “geometric proofs” two lines may be “multiplied” in the sense of rectangle formation. Whereas in the framework of the *Elements*, the separation is clearly kept between the geometric and the arithmetic books, and the kinds of proofs used in each, in the framework of Islam mathematics, and certainly later on in medieval European mathematics, we find proofs of both types mixed

together in various contexts.⁵ Among the interesting changes that we shall notice below is that arithmetic proofs started to be increasingly used also for propositions originally appearing in Book II.

3.3. Visible and Invisible Figures

A possible reaction to any criticism against the geometric algebra interpretation of Book II is to ask for a coherent, purely geometric interpretation of the meaning and usage of this collection of propositions seen as a whole. One illuminating such interpretation has been suggested by Ken Saito (Saito 2004 [1985]), and it is also relevant for our discussion below. Saito's interpretation is related to the twin-like relation already mentioned above between pairs of propositions such as II.5-II.6 or II.9-II.10. Similar relations can be shown to hold, respectively, for the pairs II.2-II.3, II.4-II.7 and II.1-II.8. We saw that in the algebraic interpretation these pairs of twin propositions may be understood as representing one and the same algebraic expression. But this immediately raises the question why would the same expression require two different propositions to express it. This would seem to go against the gist of the algebraic perspective as known to us nowadays, in which precisely such repetitions become unnecessary. One of Saito's interesting insights is that the geometric context alone provides a very coherent and sufficient explanation for the existence of these twin propositions that obviates the need for an algebraic addition (Saito 2004 [1985], 157-160). Indeed, Saito points to several places in the *Elements*, in other books of Euclid, and in Apollonius' *Conica*, where two different, but strongly related, geometric situations are proved with the help of twin propositions from Book

⁵ The distinction between the two kinds of proofs has efficiently been used in (Oaks 2011) for the case of Islam mathematics.

II. An example of this appears in propositions III.35-III.36 of the *Elements*, which deal with areas of rectangles built on segments of lines that intersect with each other and with a circle. In III.35 the lines intersect *within* the circle, whereas in III.36 they intersect *outside* it. Two diagrams appearing in the proofs of the propositions and related to this point are the following:

III.35:

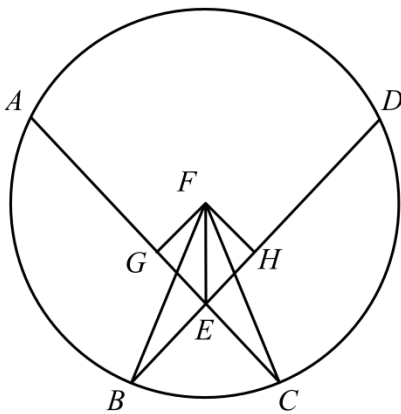

III.36:

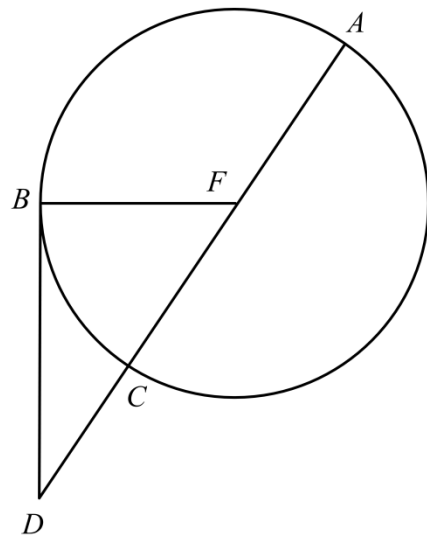

Figure 12

In III.35 the line AC is cut into equal parts at G and into unequal ones on E , and thus II.5 can be applied. In III.36, the line AC is bisected at F and DC is added to it, and thus II.6 can be applied. Notice then, that not only the *relations between the lengths* here is important, but above all their *geometric arrangement*. Thus, Saito concludes that Euclid considered lines and areas not as representations of abstract quantities that can be freely manipulated according to general rules, but specifically as geometric entities, the mutual arrangement of which is significant for the propositions considered.

Saito's analysis shows that a purely geometric interpretation of Book II does full justice to Euclid as a conscious planner of the mathematical edifice of the *Elements*.

In later books of the collection we encounter geometric situations that require the support of lemmata such as those put forward in advance in Book II in order to complete the proof or the construction at stake. The very singling out of these results as worthy of separate consideration in advance appears in retrospect as an under-acknowledged token of Euclid's great insight. I say this, because these lemmata came to be used significantly not only where originally intended, but also (as Saito shows) in Euclid's *Data* and, somewhat later, in Apollonius's *Conica*. And as the mathematician Doron Zeilberger emphasized recently, "A Good Lemma is Worth a Thousand Theorems", precisely because, while trivial in appearance or easy to prove, once stated, the insight encapsulated in a good lemma allows for its application in a wide variety of unexpected contexts, and this was indeed the case with Book II.⁶

Another aspect of Saito's analysis concerns the distinction between visible and invisible figures in the diagrams of the *Elements*. This important point is also connected with the issue of distributivity which I discuss in further details in [LC2]. Here I mention it only briefly. Recall that the geometric fact to be proved in II.1 can be schematically stated as follows (referring to Figure 1 above):

$$R(A,BC) = R(A,BD) + R(A,DE) + R(A,EC). \quad (\text{eq. 1})$$

The proof itself, on the other hand, is based on (i) taking a segment $BG = A$, (ii) constructing the parallelograms and proving on purely geometric grounds (using I.34) that $DK=A=EL$, and (iii) then realizing that, according to the diagram:

⁶ See Doron Zeilberger, Opinion 82: "A Good Lemma is Worth a Thousand Theorems". Written: Aug. 14, 2007; Downloaded May, 02, 2012: <http://www.math.rutgers.edu/~zeilberg/Opinion82.html>: "Theorems are nice, but they are usually dead-ends. A lemma may be 'trivial', or easy to prove once stated, but if it is good, its value far surpasses even the deepest theorems."

$$R(BG,BC) = R(BG,BD) + R(DK,DE) + R(EL,EC). \quad (\text{eq. 2})$$

So, what is the big difference between (eq. 1) and (eq. 2) and in what sense does the latter prove the former? Notice, in the first place, that proving $DK=A=EL$ is fundamental since otherwise the three rectangles in the figure cannot be concatenated into a single one in (eq. 2). But what Saito draws our attention to, in particular, is the fact that the rectangles used in (eq. 2) are all “visible” in the diagram, whereas those of (eq. 1) are “invisible”. Situations like that of (eq. 2) appear frequently in the *Elements* and the distributivity of the construction of parallelograms is used there without any further comment. A most prominent example appears in the proof I.47, whose well-known diagram is the following:

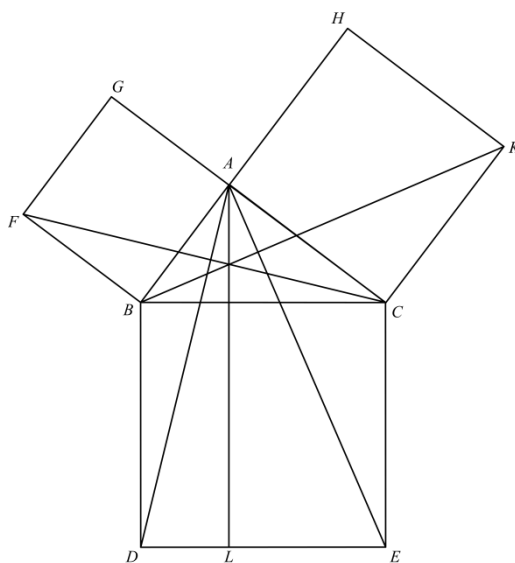

Figure 13

A crucial step in the proof is that

$$\text{Sq}(BC) = R(BD,DL) + R(CE,LE), \quad (\text{eq. 3})$$

and this step is taken in Euclid’s text without any special comment. In other words, situations embodied in (eq. 2) and (eq. 3) involve *visible* figures and hence do not require further justification other than what the figure itself shows. The situation

embodied in (eq. 1), in contrast, does require a proof precisely because the rectangles involved are, as indicated by Saito, *invisible*. In Book II, then, Euclid shows how the properties of invisible figures can be derived from those of visible ones “for one can apply to the latter the geometric intuition which is fundamental of Greek geometric arguments” (Saito 2004 [1985], 167). In the texts discussed below the awareness to this clear distinction is not strictly kept, and the blurring of borders between the two kinds of figures runs parallel to the processes of blurring of borders between geometric, arithmetic and proto-algebraic ideas.

4. Book II in Late Antiquity and in Islamic Mathematics

Medieval readers, translators and editors of the *Elements* were acquainted with various kinds of commentaries and additions, and not just with the original Euclidean text such as described above for the particular case of Book II. In this section I present some versions of results related to Book II, written in late antiquity and in the mathematical culture of Islam, and that circulated in Europe since the 12th century. The texts discussed here had a direct impact on the way that the results of Book II came to be interpreted, reproduced, and disseminated in mathematical texts in the middle ages.

4.1. Heron’s Commentary of the *Elements*

Alternatives to Euclid’s proofs started to appear already within Greek mathematical culture itself. It has been speculated that arithmetical versions of some propositions in Book II circulated at the time of Diophantus and perhaps even earlier (Vitrac 2004, 22). Also, a number of scholia to the *Elements* include an arithmetic rendering of II.5, with values $AB=10$, $AC=CB=5$, $AD=8$ and $DB=2$ (Heiberg & Menge 1883-93, Vol. 5,

234-236), but their exact dating and authorship is a debatable matter (Vitrac 2003).

What can be asserted with relative certainty is that Heron of Alexandria, who at the end of the first century A.D. wrote a *Commentary* of the *Elements*, presented original, alternative proofs to many propositions in Book II. These proofs provide a good illustration of how Euclid's arguments started to be transformed from quite early on. Since Heron's text was known, either directly or indirectly, to some of the medieval authors about whom we shall speak below his proofs are worthy of examination here.

Reconstructing the exact contents of Heron's text is not a straightforward task, since only very meager fragments have survived in Greek (Vitrac 2011). The main available substantial source for the existing reconstructions is found in a commentary to the *Elements* written by Abu'l Abbas al-Fadl ibn Hatim al-Nayrīzī (c. 875-c. 940). This commentary (which we discuss below) was one of the earliest to be written in Arabic and it preserved a considerable number of extracts from Heron's book (Heath 1981 [1921], 309-310). The medieval authors discussed in this article became acquainted with Heron's ideas via al-Nayrīzī's commentary, and hence it seems reasonable to rely on it for our discussion here. That being said, it is nonetheless important to keep in mind that more recent historical research has stressed the difficulties in asserting the ways in which the extant Latin and Arab manuscripts reflect the original text of Heron (Busard 1996b, Brentjes 2001a).

As already mentioned, Euclid had proved each proposition in Book II separately on the basis of results of Book I alone. Heron followed a different approach. He asserted that II.1 is the only one among the fourteen propositions that "cannot be proved without drawing a total of two lines". As for the remaining propositions, however, he stated that "it is possible that they be demonstrated with the drawing of one sole line", and he suggested alternative proofs that do not rely anymore on Book I. Rather, he

relied in each case on propositions from the same Book II that he gradually proved as he went along (Curtze 1989, 88-89). Thus, II.1 appears here as the basic statement of a general law of distributivity of area-formation over addition, a law whose proof is purely geometric, and from which all other propositions in Book II can be derived. Propositions II.2-II.3 appear as particular cases of II.1, and II.4 as directly derivable from it (see [LC2]). Hence, implicitly, also these propositions derive their validity from geometry, but at the same time they embody situations which Heron saw as arithmetic and illustrated with numerical examples. Along the proof he also referred to rectangles and squares constructed on the various segments (or, as he phrased it “the surface that the two lines CD , DB enclose”), but such figures are truly invisible, in the sense of Saito, i.e., they are never actually drawn and it is left to the reader to imagine them. In addition, Heron stressed that each proposition can be proved in two different ways, namely by analysis and by synthesis. I will present now the details of Heron’s proof of II.5, while focusing only on the second of these two components, namely synthesis.

Heron’s proof for II.5 relies directly on II.2-II.3, rather than on propositions in Book I, as in Euclid’s original. Heron draws a line AB , with two additional points D and C indicated on it, and with C bisecting the line, as follows (Curtze 1989, 96)⁷:

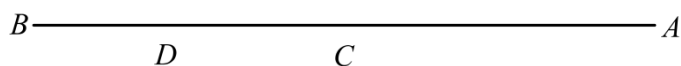

Figure 14

The core of the proof can be visualized in terms of two simple steps: (1) decomposing the square on BC into smaller pieces; (2) reassembling the pieces

⁷ And for an English translation see (Lo Bello 2009, 32).

into the rectangle on DA, DB and the smaller square on DC . Graphically this amount to the following (I am using figures that do not appear in the text):

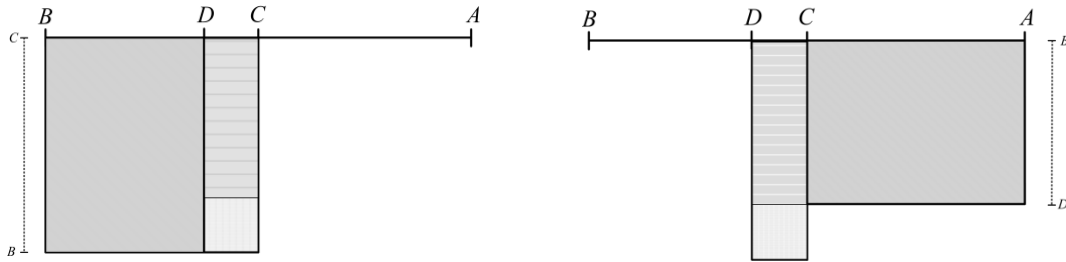

Figure 15

Schematically, Heron's argument can be summarized as follows:

- (c.1) By II.2: $Sq(CB) = R(CB, DB) + R(CB, CD)$
- (c.2) But, by II.3 $R(CB, CD) = R(CD, DB) + Sq(CD)$ (since $BC = DB + CD$)
- (c.3) Hence $Sq(CB) = R(CB, DB) + (R(CD, DB) + Sq(CD))$
- (c.4) But $AC = CB$
- (c.5) Hence $Sq(CB) = R(AC, DB) + (R(CD, DB) + Sq(CD))$
- (c.6) But by II.1 $R(AC, DB) + R(DB, CD) = R(AD, DB)$
- (c.7) Hence $Sq(CB) = R(AD, DB) + Sq(CD)$, Q.E.D.

Historians have identified Heron's proofs as early instances of using algebraic techniques in geometry, and this assessment remained unchallenged even in critical analyses of "geometric algebra" (see, e.g., Fried and Unguru 2001, 20-21). This way to interpret Heron's work, however, seems to me misleading, as I find it hard to see this approach as "algebraic" in any possible sense of this word. In the proof just presented, as well as in others in Book II, Heron added areas to areas or decomposed a square into geometric components, and then manipulated the parts in order to reconstruct a different one. On the one hand, these are just legitimate *geometric* operations also found in other parts of the original Euclidean text. On the other hand,

there is here an interesting twist of ideas whereby Heron extended the scope of Euclid's norms, in the sense that he applied to invisible figures manipulations that Euclid had legitimately applied only to visible ones. Indeed, as we saw above, the whole idea of Book II was to provide tools that created a sound basis for doing these kinds of geometric manipulations wherever needed, and now we find here the manipulation of invisible figures being done already *within* Book II. Moreover, one cannot overlook the important difference embodied in the fact that Euclid's proof is in essence *constructive*, while Heron's is *operational*: what I mean by this is that Euclid starts with an elaborate construction that needs to be completed before starting the apodictic part of the proof, whereas Heron proceeds straightforwardly from the divided line to the conclusion, simply by operating (i.e., adding and comparing areas) with squares and rectangles built on the segments appearing in the proposition (and using some previous propositions as well). In fact, it is quite clear that Heron's diagram alludes to those appearing in the arithmetical books of the *Elements*, which typically comprise just collections of segments which are referred to in the proof but are not used for any kind of construction. Thus, Heron's proof are different from Euclid's in important senses, but not in the sense of being algebraic rather geometric. Indeed, they are not even "arithmetic proofs" in the sense explained above, since two lines multiplied give rise to a rectangle and not to a third line. Heron's proofs are not less geometric than Euclid's, but rather *differently* geometric, and in a meaningful manner at that.⁸

Given this different geometric approach, some have speculated about the possibility

⁸ (Vitrac 2005, 6 ff.) speaks about two contrasting styles of geometrical proof in Greek mathematics: "demonstrative" vs. "algorithmic". Without wanting to make too much of word-choice, and without the benefit of the much broader scope of Vitrac's analysis, I think that for the case of Book II, at least, the contraposition of "constructive" vs. "operational" is more adequate to encapsulate the difference between Euclid's and Heron's proofs.

that Heron's proof had its sources in Pythagorean ideas from a time in which arithmetic and geometric practices were less clearly separated than what they came to be later on, as in the Euclidean text (Vitrac and Caveing 1990, 369). At any rate, it seems evident that the operational character of Heron's proof, even though it is *geometrically* operational, more conveniently prepares the road for a possible arithmetic, and later algebraic, readings of the propositions in Book II. As we shall see below, this road was indeed taken by later readers of Euclid's text and of Heron's commentary. But it is important to stress these kinds of differences between two geometric approaches (Euclid's and Heron's) since it is precisely through this kind of nuances that we come to understand the slow process through which algebraic-like thinking entered geometry and in particular the kind of geometry developed in Book II.

4.2. **Al-Khwārizmī and Abū-Kāmil**

The development of procedures for solving problems involving unknowns and their powers was a central contribution of the mathematicians in the culture of Islam. The terms "Islamic algebra" or "Arabic algebra" can be associated with this tradition. Their most well-known contributions are dated not before the beginnings in the 9th century, but it is likely that some of the earlier ideas began as practical traditions that were cultivated and transmitted orally over many centuries (Høyrup 1986). It is obvious, at any rate, that the Islamic context must be explored in any attempt to follow the incorporation of arithmetic, algebraic or proto-algebraic ideas into later versions of Book II. One must keep in mind, of course, that the transmission of the Arabic *Elements* involved a highly complex network of translations, editions, commentaries and reception, about which knowledge continues to be somewhat

limited and contested (Brentjes 1994, 1996, 2001a). The current scholarship typically refers to two basic Arabic translations of Books I–XIII, that gave rise to separate textual traditions. One, composed before 805, is attributed to Al-Ḥajjāj ibn Yūsuf ibn Maṭar (fl. between 786–833). A second one, composed by Ishāq ibn Ḥunayn (ca. 830–910/11), during the last third of the ninth century, was later edited by Thābit ibn Qurra (ca. 830–901). I will discuss here ideas of Book II that appear in the works of al-Khwārizmī, Abū Kāmil, Thābit ibn Qurra, and al-Nayrīzī. In all these cases, these ideas appear in contexts that sensibly differ from the original Euclidean one. Moreover, in each case we find different approaches to the way in which the result can be used and interpreted from an algebraic or arithmetic perspective. These four mathematicians do not exhaust the variety of relevant texts from the Islamic tradition, but they were among the most commonly read in medieval Europe and this is the reason for focusing here on their works.

The famous *Al-kitāb al-muḥtaṣar fī ḥisāb al-jabr wa-l-muqābala* (“The Compendious Book on Calculation by Restoration and Confrontation”) was written by Muḥammad ibn Mūsā al-Khwārizmī (c. 780–850) in the early ninth-century on the exhortation of the caliph al-Mamun. As it is well known, al-Khwārizmī presented here rules for solving problems that involve squares of an unknown quantity, and he then added geometric proofs to justify some of the rules. Although it seems unlikely that he was not aware of some of the existing translations of Euclid’s text, the fact is that he did never directly refer to or otherwise mention the *Elements* (Djebbar 2005, 34–36). Neither did he explicitly state or prove results of Book II in any of his works. Many of the geometric proofs found in his texts bear similarities with the Euclidean propositions, but they are used in a less rigorous and more intuitive or “visual” manner than in the original. A well known example is the use of a result similar to II.5

in relation to the problem known as “the square and twenty-one numbers equal ten roots of the same square”. Here we find an early, interesting case of embedding the core of II.5 in a typical Arabic “algebraic” context.

Al-Khwārizmī’s procedure to solve this problem is described as follows (Rosen 1831, 11):

Halve the number of the roots; the moiety is five. Multiply this by itself; the product is twenty-five. Subtract from this the twenty-one which are connected with the square; the remainder is four. Extract its root; it is two. Subtract this from the moiety of the roots, which is five; the remainder is three. This is the root of the square which you required, and the square is nine. Or you may add the root to the moiety of the roots; the sum is seven; this is the root of the square which you sought for, and the square itself is forty-nine.

The diagram used to endorse the validity of this procedure is reminiscent but not identical to the Euclidean one for II.5. It involves a square AD , whose side AC represents the unknown magnitude. In the diagram there is also a rectangle HT , one of whose sides, HN , equals AC .

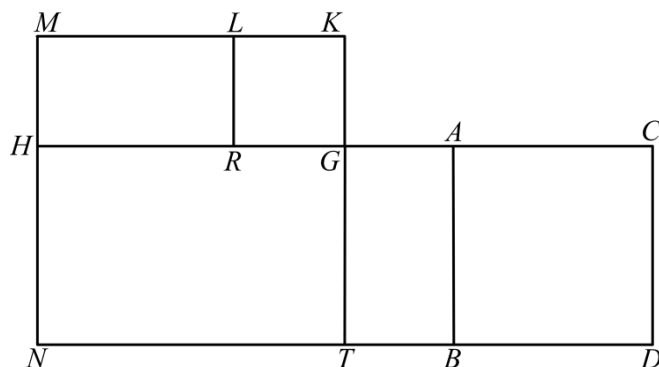

Figure 16

The diagram accounts for the problem in the sense that rectangle HB and square AD together build a larger rectangle, HD , that represents 10 times the unknown

magnitude AC , while HB alone is assigned the value 21. Al-Khwārizmī's argument, from here on, can be schematically rendered as follows:

- (d.1) Bisect HC at G , and construct square MT with side equal to HG . Since HG is of length 5, then the area of MT is 25.
- (d.2) Construct $KMHG$ with $KG = GA$. Here $KR = \text{Sq}(GA)$.
- (d.3) Now, we have cut HC into equal segments at G and into unequal segments at A . Euclid's II.5 can be applied here, so that: $\text{Sq}(HG) = R(HA, AC) + \text{Sq}(GA)$. Hence, $MT = HB + KR$.
- (d.4) Thus, the value of KR is 4, and its side is 2. And since $GK = GA$, it follows that AC is 3, and this is the side we were looking for.

Al-Khwārizmī is thus using here the main idea behind II.5 in the framework of a specifically arithmetic case. He freely associates numerical values to what for Euclid are continuous magnitudes (line segments), and then he can obtain, with the help of II.5, another value that is associated to a certain square. Of course, this association crucially depends on the conceptions of number typical of Islam mathematics, and which differ from the classical Greek ones. For al-Khwārizmī, as for most of his successors, any kind of positive quantities arising from calculations, including fractions or irrational roots, would count as legitimate numbers. In the last step of the argument, the side is used to find the value of the unknown magnitude. This approach clearly deviates from Euclid's consistent separation between geometric and arithmetic contexts, and it will have significant consequences over later developments. At the same time, however, II.5 itself has not lost here its purely geometric character in any way. On the contrary, al-Khwārizmī is clearly implying that by reducing his problem to a geometrical context he is bestowing theoretical legitimacy to his solving algorithm. He may have wanted to appeal to certain readers with a more theoretical

orientation, though perhaps not all of his readers would think of this as a necessary requirement. It should be noticed that, as in any algebraic solution of a quadratic equation, the crucial step in al-Khwārizmī's procedure is that of "completing squares", only that in this case, this completion is a purely geometric procedure, rather than a symbolic, algebraic one as it will be much later in the algebraic tradition of the 17th century.

An interesting question that has been a matter of lively debate among historians concerns the sources of the ideas appearing in al-Khwārizmī's *al-jabr wa-l-muqābala* and the degree of originality of his own contribution. This is true for both the algorithms and the kind of geometric justifications illustrated above.

In the past it was common to assume Greek roots and a direct connection to the *Elements*, but more recently, historians also started to indicate more prominently Indian and Central Asian influences. Following a different direction, Jens Høyrup has also suggested a possible connection with Babylonian traditions of problem-solving that were alive and influential up until the European Renaissance (Høyrup 1986, 2001). One way or another, ideas from Book II continued to appear repeatedly in later books of the Arabic algebraic tradition, typically as part of a geometric justification similar to what we have just seen with al-Khwārizmī. Of the highest relevance to our discussion here is the example of Abū Kāmil (c. 850-930) in his *Kitāb fī al-jabr wa al-muqābala*⁹, a treatise written around 900. Abū Kāmil presented in a systematic way

⁹ A Latin version is extant which dates from the 14th century (Sesiano 1993). I will be referring to this Latin text, which most likely reflects what was available to the European mathematicians we shall be discussing below. There is also a Hebrew version with comments by Mordechai Finzi (died 1475) which seems to have been a translation from a Spanish version, but no such Spanish version has been preserved. See (Levey 1966; Weinberg 1935).

methods and results found in al-Khwārizmī, while at the same time incorporating a visible influence of the arithmetic books of the *Elements* (Moyon 2007; Oaks 2011). His treatise was widely read by European medieval mathematicians, and its influence is clearly visible, particularly concerning the questions that we are discussing in this article.

Abū Kāmil started by discussing the six cases of problems with squares as introduced by al-Khwārizmī. In providing geometric arguments to justify the validity of his methods of solution, however, he followed the Euclidean source and its standards much more closely than his predecessor. As a matter fact, in the text we find for most problems two geometric justifications for each case, one closer in style to al-Khwārizmī and one relying directly on a result from Book II. This may reflect a desire to meet the requirements of two different kinds of readerships: one of “practitioners” and another one of “theoreticians”. Still, in both cases Abū Kāmil assigned numerical values to lines and areas without any limitation, very much like al-Khwārizmī had done before him. Let us see the two proofs for the example of “the square and ten roots of the same square equal thirty nine numbers”, where Abū Kāmil relied on II.6. This example, also taken directly from al-Khwārizmī, is historically important since it was repeated, with slight variations, by many mathematicians both in the Islam and early European algebraic tradition (Dold-Samplonius 1987).

The accompanying diagram is the following (Sesiano 1993, 327–328):¹⁰

¹⁰ See also Oaks 2011, 255-256.

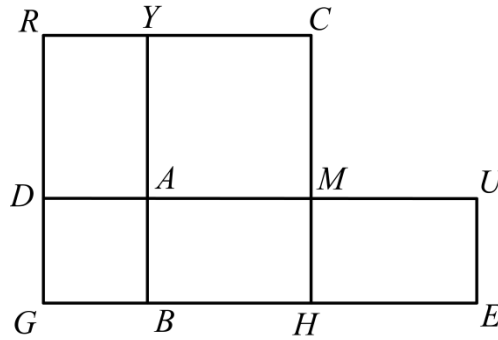

Figure 17

In the first proof, the square $ABGD$ represents the square of the unknown and to this the rectangle $ABEU$ is attached and it is taken to represent ten roots. This means that the line BH represents the number ten since the rectangle share with square $ABGD$ the line AB . Now, in the argument rectangles and squares, as well as line segments are taken to represent numbers, satisfying the conditions stipulated in the problem, namely the square of the unknown, $ABGD$, together with ten roots, $ABEU$, is thirty nine. Abū Kāmil's argument can be schematically rendered as follows:

(e.1) $R(AB, BE) + \text{Sq}(GB) = 39 = R(EG, DG)$.

(e.2) But $GD = GB$, so that $R(EG, GB) = 39$.

(e.3) Bisect BE at H . Accordingly, $HB = 5$, and $\text{Sq}(CB) = 25$.

(e.4) But BG is appended to HB in a straight line. Hence, [according to II.6]¹¹:

$$R(EG, GB) + \text{Sq}(HB) = \text{Sq}(HG).$$

(e.5) Since $R(EG, GB) = 39$ and $\text{Sq}(HB) = 25$, then $\text{Sq}(HG) = 64$.

(e.6) Thus, $HG = 8$, and line $HB = 5$. Finally, $GB = 3$, and $\text{Sq}(GB) = 9$. **Q.E.D.**

The second argument relies on the equality of the rectangles RA and ME , which by construction are both equal to rectangle AH . Hence, since DE is 39, then the three surfaces, MB , BD , DY taken together are 39. In addition, AC is 25, since HB is 5, from whence it follows that GC is 64, and GH is 8, and, finally, GB is 3.

¹¹ "... sicut dixit Euclides in secundo tractatu libri sui".

In the first proof just described, the square $HGCR$ and the segment YB are not even mentioned. Indeed, they are not needed. These are, as in Euclid's proofs, "invisible figures" that are only implicitly referenced (i.e., $HGCR$ is the square on SG). Thanks to the use of II.6, one does not actually need to draw the entire diagram in order to follow the proof. The diagram is drawn in full, however, because in the second proof it is needed in order to follow the argument. Abū Kāmil describes this second proof as one that is meant to explain the problem "so that it becomes apparent to your eyes". Indeed, the fact that the three surfaces MB , BD , DY taken together are 39 can be seen directly on the diagram, based on the way in which it was constructed. The first proof, in contrast, is based on a proposition in Euclid which gives a rule that is applied "blindly", as it were. The first perhaps is perhaps stronger in logical rigor, but it lacks the visual transparency that characterizes the second proof.¹²

There is a basic tension clearly reflected in these proofs, one which actually underlies the entire treatise. This is the tension arising from the combination, within one and the same text, of results and methodological approaches taken from the arithmetic parts of the *Elements* (as well as from other, earlier arithmetic traditions) with results and proofs originally meant to deal with continuous magnitudes, such as those of Book II. Arabic numbers were of a more general kind than those handled in Euclid's arithmetic books, so that the latter could not fully account for the rules of calculation for which Abū Kāmil was attempting to provide a theoretical account. The results of Book II helped Abū Kāmil complete the picture, but in doing so, he subsequently affected the

¹² Besides this method of solution for finding the *thing*, whose validity is proved in two different ways, Abū Kāmil also introduced a second method of solution directly yielding the value of the *square*. Although highly interesting in itself, it is beyond the scope of the present article. See (Sesiano 1993, 329-330; Moyon 2007, 310).

way in which this collection of results was conceived, while broadening the scope of its intended applications (Oaks 2011). (And see also [LC2].)

We have seen how in these two mainstream texts of early Islam mathematics, al-Khwārizmī's and Abū Kāmil's, an intrinsic connection between the emerging techniques of Islam algebra and the theorems of Book II was made explicit. As part of this fundamental connection, a clear conceptual hierarchy was implicitly reflected whereby geometry appears as a main source of mathematical certainty, whereas the newly developing proto-algebraic ideas receive full legitimation from geometry. Within this entire picture, and in spite of the broader scope of ideas within which it came to be applied, Book II was applied as an important source of mathematical reliability which did not thereby lose its essentially geometric character. It is also in this way that it would be eventually perceived by the many readers of these treatises in Europe medieval mathematical culture.

4.3. Thābit ibn Qurra

Like al-Khwārizmī, also Thābit ibn Qurra worked in Baghdad under the patronage of the caliph. He was active in the second half of the ninth century, at a time when many Greek texts started to be translated and incorporated into the available body of mathematics known in the Arabic culture. Ibn Qurra, who as already indicated had edited one of the early translations of the *Elements*, also discussed the solution of problems with squares of unknowns quantities in a treatise entitled *Qawl fī taṣḥīḥ masā' il al-jabr bi'l-barāhīn al-handasīya* ("Account of the Correctness of Problems of Algebra by Geometric Proofs"), which is of particular interest for our survey here. This treatise presented general solutions for three of the six standard cases previously

treated by al-Khwārizmī (though without mentioning al-Khwārizmī), and, like al-Khwārizmī’s text, it also provided geometric justifications for each of the procedures presented. Like Abū Kāmil somewhat later, Ibn Qurra referred explicitly to the propositions of Book II of the *Elements* as his basis for legitimation. But, unlike these two mathematicians, Ibn Qurra discussed various cases in an abstract manner that did not involve specific numerical instances (either in the formulation or in the solution). All the while, he translated each step of the procedures he discussed into a corresponding component of the geometric diagrams of II.5 and II.6. In this way he remained at the abstract level that involved reference to general squares, roots and numbers, rather than to specifically measured ones. This can be better understood by looking at the case he “verified” with the help of II.5, which is the already mentioned case: “square and numbers equal roots of the same square”.

In his presentation Thābit referred to the following diagram (Luckey 1941, 106–107):

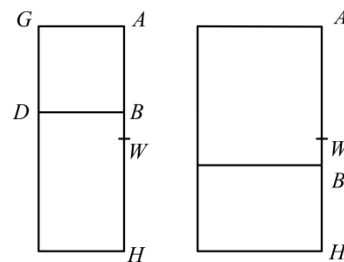

Figure 18

The square of the unknown quantity is represented here by the square $ABDG$, while the line AH “is measured by as many units as there are roots” in the given problem. By completing the rectangle GH we obtain a figure that represents the number of roots, and if we subtract the square BG , then DH represents the “numbers” in the problem. From here the argument proceeds as follows:

- (f.1) DH equals AB times BH , whereas AH is also known. In other words, what we have is a given line AH , which is cut at B , in such a way that $R(AB, BH)$ is known.
- (f.2) Bisect now AH at W . By II.5, $R(AB, BH) + \text{Sq}(BW) = \text{Sq}(AW)$.
- (f.3) But AW is known (since AH is known) and hence $\text{Sq}(AW)$ is known, and also $R(AB, BH)$.
- (f.4) Thus, we also know now $\text{Sq}(BW)$, and hence we know BW .
- (f.5) If BW is subtracted from AW (as in the figure on the right) or added to AW (as in the left), then we obtain AB as a known quantity, which represents indeed the root we are looking for.

Thābit's algebraic procedure for solving this case is based, as we see, on completing a square and then adding or subtracting from the value of the number of roots in the problem. This is quite similar to what we saw in the two previous examples. When explaining the rationale behind the procedure in terms of geometrically completing the square on BW , the main trick comes from II.5. But Thābit did not just use geometric methods in order to solve a specific problem, or to legitimate known procedures. Rather, he essentially *identified the two methods with one another* by stressing that his arguments "are in accordance" with those developed by the "algebraists" (Luckey 1941, 95). This is a subtle step beyond the views implicit in al-Khwārizmī's and later in Abū Kāmil's approach, and Thābit's highly influential status within Islamic mathematics no doubt helped disseminate it. It thus seems reasonable to assume that it may have contributed to strengthening views of Book II as a collection of techniques *directly related* to the gradually developing algebraic procedures, rather than just supporting it from outside.

4.4. Al-Nayrīzī

Another version of II.5 in the mathematical culture of Islam that is worthy of attention here is the one appearing in al-Nayrīzī's commentary to the *Elements*, dating from the early tenth century, which was one of the earliest such commentaries to be written in Arabic.¹³ In his text, al-Nayrīzī incorporated idiosyncratic additions and changes to the original text. Some of these comprised either a commentary on the Euclidean proof or an alternative proof. Al-Nayrīzī's attributed them to Heron's *Commentary*. The most noticeable kind of additions to Book II were numerical examples that illustrated each proposition. In the case of II.5, for instance, the numerical example is of a line AB representing the number 10, which is then divided into two equal parts, 5 and 5, and also into two unequal parts, 7 and 3. Thus, $5 \times 5 = 25$ equals $7 \times 3 + 2 \times 2$.¹⁴

A second important kind of addition that al-Nayrīzī incorporated into the Euclidean text appears in Book IX, where, as a series of comments to IX.16, he included arithmetic versions of I.1-II.4 (Curtze 1899, 204-207). It is evident that merely by placing these propositions in the context of one of the arithmetical books of the *Elements*, and by reformulating these four propositions in terms of numbers rather than in terms of lines, al-Nayrīzī was making a strong statement about the way in which the knowledge presented in Book II, particularly concerning distributivity,

¹³ This text in its various extant manuscripts and translations has had a somewhat convoluted history (Brentjes 2001b), which I will not delve into here. I will refer to the text as rediscovered and published in Latin translation in (Curtze 1899). For details see also (Lo Bello 2003a; 2009); (Tummers 1994).

¹⁴ In Curtze's late 19th-century edition of this text, Al-Nayrīzī's commentary was accompanied by a footnote in which he formulated the original Euclidean text together an algebraic rendering of the proposition (Curtze 1899, 94). Even here this algebraic rendering is anachronistic. Reinterpreting a geometric result in arithmetic terms (as Al-Nayrīzī did) is not yet the same as reinterpreting it algebraically.

should (or at least could) be seen.¹⁵ But al-Nayrīzī went much further than that and he gave fully *arithmetic proofs* of these four propositions, all of which embody properties of distributivity. He proved them simply by counting and comparing the numbers of units in each of the products involved (see [LC2] for details).

One may speculate, of course, about the possibility that all or some of these additions and modifications were suggested to al-Nayrīzī directly by his own reading of Heron's operational rendering of the Euclidean proofs in Book II. Heron's approach was, as already stressed, operational and yet fully geometric. But it lent itself quite easily to a direct translation into arithmetic, in a way that Euclid's proof did not. Al-Nayrīzī may have as well been influenced by some other, unmentioned texts that circulated in late antiquity or in the Islam context. Thus, for instance, in an encyclopedic Arabic text published around 960 by the Ikhwān al-Ṣafā' fraternity, the *Rasā'il* (or epistles), we find the same kinds of numerical examples (Goldstein 1965, 154-157). The text in this work betrays the clear influence of Nicomachus' *Introduction to Arithmetic*, written in the first century AD, and it also formulates the propositions of Book II directly as propositions about numbers, rather than lines. However, since there are no proofs at all in this text, we cannot say in more precise terms what the writer of the text had in mind concerning the nature of numbers and their relation to geometry. This text, moreover, was probably unknown to the medieval mathematicians discussed below.

The important point, however, which can be asserted with certainty, is that al-Nayrīzī

¹⁵ Neither Curtze nor – to the best of my knowledge – any other later commentator has called attention to the remarkable fact that al-Nayrīzī's IX.16 is an addition to, and indeed a generalization of, Euclid's IX.15, and that, incidentally, an interesting feature of Euclid's proof of IX.15 is its reliance on what seem to be arithmetic versions of II.3 and II.4 (Heath 1956 [1908]), Vol. 2, 404-405). Campanus, following al-Nayrīzī, included arithmetic versions of propositions of Book II as additions to the same IX.16. I discuss this point in greater detail in [LC2].

reached few, but influential medieval readers, and in important cases his examples and additions were cited in texts written by those readers. Indeed, al-Nayrīzī's text was translated into Latin by Gerard of Cremona (c. 1114 – 1187), who used the Latinized version of the name, Anaritius (Lo Bello 2003a).¹⁶ This Latin version does not seem to have been widely read in medieval Latin Europe, but we know that it was seriously studied by at least two important scholars: Roger Bacon (c. 1214–1294) and Albertus Magnus (c. 1206-1280) (Hogendijk 2005). Influenced by the text, Albertus wrote his own commentary of the *Elements*, comprising a paraphrase of Books I-IV as well as philosophical discussions (Lo Bello 2003b; Tummers 1980). These two authors, who played an important role in the spread of Greek and Arabic science in Western Europe, were certainly enthusiastic about mathematics, and Gerard's translation of al-Nayrīzī was an important source for their knowledge of geometry. But this knowledge of geometry was somewhat limited and it can be said that both of them failed to appreciate the importance of al-Nayrīzī's text. And yet, al-Nayrīzī's original text became indeed influential, at least via Jordanus Nemorarius and Campanus de Novara, as we shall see below.

These are a very few examples from among a much broader mathematical literature of the culture of Islam. They make it clear, however, that the ways in which the ideas of Book II were handled at the time created and helped disseminate an image of Book II in which the original, purely geometric character intended by Euclid had already been already broadened. This is not to say that the propositions of Book II lost their clearly geometric anchoring. Yet as they began to be incorporated in texts that

¹⁶ One interesting point of his Latin version is that in Al-Nayrīzī's additions to IX.16, products of numbers are called "areas" (*superficiales*).

suggested, either implicitly or explicitly, that they are about properties of numbers, at least to the same extent that they are of lines, the way was opened to additional, far-reaching changes, including possible “algebraic” interpretations. One may imagine that mathematicians of later times, say in the Renaissance, who learnt their Euclid from texts influenced by Islamic mathematics while being also trained in algebraic methods, might naturally tend to read the propositions of Book II as embodying essentially algebraic ideas. In the mathematical culture of the Latin Middle Ages we still find a more fluid and less consolidated mixture of ideas of various kinds around Book II. An analysis of the ways in which its propositions were understood is very challenging and rewarding. The remainder of this article is devoted to such an analysis.

5. *Book II in the Early Latin Medieval Translations of the Elements*

Euclid’s *Elements* enjoyed a prominent position in the intellectual world of the Latin West. Within the history of the transmission of the Greek corpus, “no work – be it mathematical, astronomical, philosophical, or medical, no matter – had anywhere near the [same] number of Medieval versions” (Murdoch 2003, 370). “Versions”, to be sure, is the right term to be used in this context, since a large number of variants of the *Elements* circulated in Europe that deviated in various degrees from what was considered the “faithful” translation. Moreover, many other contemporary mathematical treatises incorporated portions, sometimes even relatively lengthy portions, or results, of the Euclidean text. Thus, the story of the reception of the *Elements* in the Latin West is a very complex one, which has been thoroughly studied by scholars and which continues to offer a fruitful field of historical research to this day.

It is generally accepted that prior to the 12th century, only fragments of Euclid's text circulated in Latin Europe. The best-known of these were attributed to a translation from the Greek by the late Roman philosopher Boethius (ca. 480–524). They circulated in relatively wide European circles, beginning in the 9th century, as part of a compilation usually known in the scholarship as *Geometria* I, and then in the 11th as part of a second compilation known as *Geometria* II. Only fragments of the original Boethian translation have been preserved, but it is known beyond doubt that it contained at least parts of Books I to V. The translations, at any rate, were far from problematic and the texts did not contain proofs. Most likely, the significance of Euclid's contribution was not really appreciated at this time (Folkerts 1981).

During the incipient intellectual revival associated with the Carolingian empire and in the centuries that followed, Boethius' treatises and his idea of the Latin quadrivium played a prominent role. The mediation of figures such as Cassiodorus (ca. 485–ca. 585) and Isidore de Seville (ca. 560–636) was of crucial importance as well. What is of special interest for us here is that within the quadrivial image of the mathematical sciences, it was arithmetic, rather than geometry, that had absolute primacy in terms of disciplinary importance (Guillaumin 2012). In "*Geometry* II", for instance, Boethius described the knowledge of numbers as "the high point of all philosophy" (Folkerts 1970, 138). Cassiodorus, in turn, saw arithmetic as the "origin and source" of the other mathematical sciences, which "depend for their being and existence" on arithmetic (Eastwood 2007, 192). This theoretical primacy, moreover, was further enhanced by the contemporary incipient interest in the practical aspects of arithmetic in day-to-day life.

In the early 12th century, an unprecedented amount of Greek treatises gradually became available in Latin, many of them via Arabic translations. Their impact

brought about significant changes in the world of learning at large, in its contents and in its institutions. This is the time when existing cathedral schools developed into universities at Bologna, Paris and Oxford, and when new universities were created at Cambridge and Padua. While perhaps their overall centrality receded, the quadrivial arts continued to be taught at these new universities, side by side with the new subjects and texts introduced into the curriculum (Kibre 1981). The disciplinary primacy accorded to arithmetic over geometry within the mathematical sciences, to be sure, remained unchanged.

Translations to Latin from Arabic or Hebrew original works aroused no less enthusiasm than those of Greek texts. But whenever their texts were available, Greek authors were invariably seen as the main authorities, and were considered to be more reliable than their Islamic counterparts. The latter were more often than not used as support or commentary with respect to questions of correct or false attribution to works of the ancient Greeks. In the words of Jens Høyrup (1998, 320): “Arabic texts, even when translations from the Greek, were treated as objects to be used, and not always very formally. Greek texts, on the other hand, were sacred objects and handled as such; they were normally translated *de verbo ad verbum* (so closely indeed that both the number of words and their order were often preserved ...).”

Among the earliest translations of the *Elements* from Arabic, historians usually count those of Hermann of Carinthia (c. 1100 – c. 1160) and of Gerard of Cremona (already mentioned above in relation to al-Nayrīzī). These translations, however, were not frequently read and copied. According to the currently accepted scholarship,¹⁷ the

¹⁷ The introduction to (Busard 2005) contains a clear and well-organized summary of the rich and scholarly impressive literature that has dealt over the last thirty years with the issue of the Latin versions of the *Elements*. The reader may also consult the following: (Brentjes 1997/8, 2001a);

texts that provided the basis for the main corpus of manuscripts that spread throughout Western Europe over the 12th and 13th century were produced by Adelard of Bath (fl. 1116-1142), by Robert of Chester (fl. c. 1150), and, somewhat later, by Campanus de Novara (1220-1296). Robert's text is not a direct translation from the Arabic but rather a compilation of different texts, among them the translations of Hermann and Adelard. Campanus's text was the one that in 1482 appeared as the first printed version of the *Elements* and which became the standard source of reference for the Latin world until the 16th century when new versions were printed, based on direct translations from the Greek.¹⁸

The issues that have attracted the attention of historians investigating the Euclidean tradition in the Latin Middle Ages must be understood against this background. A main such issue concerns the ways in which the Adelard-Robert versions and the Campanus version of the *Elements* (and their derivatives) differ from Euclid's original. Thus, unlike in Euclid's original, one often finds in these texts a careful labeling of the various sections of the proof (*exemplum*, *dispositio*, *rationatio*, *conclusio*, *exempli gratia*, *rationis causa*, etc.), direct references to earlier propositions on which a proof is based, and hints about other propositions which are directly related to the one considered. On the other hand, rather than explicit proofs many texts provide only hints to the main ideas on which the arguments are based. Differences in wording and in the level of detail created the impression, shared by many at the time, that Euclid was author only of the definitions, postulates, axioms

(Busard 1983, 1984, 1996a); (Busard & Folkerts 1992); (Folkerts 2006 –Section III); (Murdoch 1968, 1971).

¹⁸ John Murdoch (1966) called attention to a very accurate twelfth-century translation of the *Elements* by an anonymous translator who also translated Ptolemy's *Almagest* from the Greek. However, there is no evidence of any substantial use of this translation. See also (Busard 1987).

and enunciations, whereas the proofs were considered to be just commentaries provided by translators or compilers (Busard & Folkerts 1992, 16).

John Murdoch (1971; 2003, pp. 372 ff.) has stressed three main concerns that were prevalent in the medieval versions of the *Elements*: didactic considerations, clarification of the logical structure of the entire treatise, and the relation of the mathematical contents to more general philosophical questions and conceptions. Two topics that received special attention in this regard were incommensurable magnitudes and the nature of the continuum (Murdoch 1968, 90-93). Accordingly, the existing scholarship has dealt mainly with the ways in which the Latin medieval tradition handled the theory of ratios and proportions, and particularly in relation with Book X (see, e.g., Rommevaux 2008). The relevance of these topics to Book II and to the questions discussed in this article, in turn, has typically received much less attention.

Of particular importance for our discussion here is the fact that the rigid separation between the realms of number and of continuous magnitudes consistently preserved in the Greek original was highly unsatisfactory for medieval mathematicians. This is interestingly manifest throughout the texts of the various Euclidean versions. Thus, for instance, while in his arithmetical books, VII – IX, Euclid strictly refrained from using the Eudoxian theory of proportions of Book V, we find instances of its use in the Latin versions, together with interesting comments related to them. We also find proofs of propositions about continuous magnitudes based on the use of particular numerical examples, for instance in Books V and X. We have already seen a similar use of numerical examples in the text of al-Nayrīzī, but in the medieval versions we also find arithmetic ideas used in the proof. Moreover, in some Latin versions of the *Elements*, the only argument given was that of a numerical example. Likewise, we can

also find examples of geometric arguments and concepts being used when discussing some propositions in the arithmetical books (for details, see Murdoch 1968, 86-90).

And yet, in spite of the importance accorded to arithmetic in the medieval mathematical landscape, and the other kinds of differences with the Greek original mentioned above, most proofs of Book II found in the Latin versions remained very close to the original Euclidean ones, or at least to their Heronian variants. It is fair to say that in general, no arithmetic or algebraic ideas were introduced *at the core* of the proofs of Book II and that the purely geometric character of the propositions was essentially preserved (the Campanus version presents a very interesting turn in this regard, but I discuss his case separately).

We can illustrate the situation by looking at how II.5 appears in the various texts in the Adelard-Robert tradition. First we can look at the so-called Adelard I version, which is most likely the first complete translation from an Arabic version of the *Elements*. We find there exactly the same geometric proof as in Euclid, based on the use of the gnomon (Busard 1983, 75-76). Also the proof of II.5 appearing in the so-called Adelard II version – nowadays considered to be a compilation attributed to Robert of Chester – remains close to the purely geometric spirit of the Greek original, albeit without repeating all the details found in Euclid. Many extant manuscripts of this version exist, and its enunciations were used by many other Latin commentators or editors, including Campanus. Many of the proofs are typical examples of providing no more than general indications about the argument, and in some of the manuscripts there are only diagrams. For II.5, the guidelines refer to the following figure and stipulate the following steps (Busard & Folkerts 1992, 132)¹⁹:

¹⁹ Unless otherwise stated, translations from Latin, Hebrew, or German are mine.

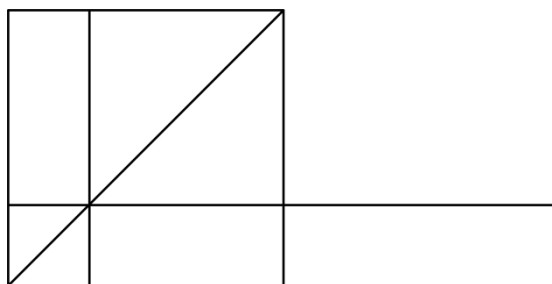

Figure 19

A square is constructed on the middle of the whole line. Through the point of the unequal section draw a line segment parallel to the side of the square, and then a diagonal in the square. Where these two lines intersect draw another parallel line [and use it to complete a rectangle]. Two equal complements are obtained, and [the rectangle] contained by the two unequal portions equals the whole gnomon. Hence, the residue between the two figures is manifestly the square [built on the segment between the two cuts].

The general indications for proofs appearing in the Robert version were subsequently elaborated in various ways. Thus, for instance, in a thirteenth-century adaptation of the text, the proofs of Book II preserved their essentially geometric spirit, but were elaborated along the cut-and-paste approach introduced in Heron's proofs (see the proof of II.5 in (Busard 1966a, 102-103)). The geometric proof based on the gnomon also appears in the translations of Hermann of Carinthia (Busard 1968, 44-45), Gerard of Cremona (Busard 1984 43-44), and in the translation made directly from the Greek (Busard 1987, 58-59).

And yet, in spite of this, some alternative to the proofs of Book II, and specifically, some arithmetically-oriented proofs did circulate in the Medieval Latin world. We find them in books other than the *Elements*, or, interestingly, in the case of Campanus, as part of additions and comments to the three arithmetic books of the *Elements*. The

next (and last) section of the article is devoted to these ideas, as they appear in the works of medieval scholars such as Abraham Bar Ḥiyya, Leonardo Fibonacci, Jordanus Nemorarius, Campanus, Gersonides and Barlaam.

6. Book II in Other Medieval Texts

6.1. Abraham Bar-Ḥiyya

I start this survey with Abraham bar Ḥiyya ha-Nasi (ca. 1065-1145), also known as Savasorda. He was a Jewish sage born in Barcelona, and probably educated in Zaragoza. Little is known of his life, but the importance of his work for the transmission of Arabic science to the Jews in Spain and to the Christian Latin West in general is widely acknowledged. He wrote Hebrew treatises in various fields of knowledge, such as philosophy, astronomy and astrology. His treatise, *Ḥibbūr ha-meshīḥah we-ha-tishboret* (חיבור המשיחה והתשבורת), a title often translated as “Treatise on Measurement and Calculation”, was a book on practical geometry (Lévy 2001, 37-42; Sarfatti 1968, 64-128). A Latin version by Plato of Tivoli appeared in 1145 under the title of *Liber Embadorum*. This Latin text introduced for the first time in Europe the techniques of Islamic algebra for solving quadratic equations, thus antedating Gerard de Cremona’s Latin translation of al-Khwārizmī’s *Algebra*. The *Liber Embadorum* was widely read and it is known to have directly influenced Leonardo Fibonacci (Clagett 1978, 1265; Curtze 1902, 5-7; Millas-Villacrosa 1931).

Bar Ḥiyya is the earliest representative of a tradition involving Jewish sages who assimilated important parts of the Greco-Islamic scientific culture and published their own works in Hebrew, mainly between the 12th and 14th century. Such works were intended as a vehicle for transmitting Arabic science to Jewish audiences not

conversant with the Arabic language. They often comprised compilations and systematic presentations of previous work, but in many cases they also presented original ideas (Levy 1997a; 1997b; 1997c). Characteristic of many of these texts is the noticeable effort made by the authors to stress their nature as practical treatises that draw their contents from the “wisdom of the nations” (חכמת הגויים) but which, at the same time, provide useful tools in the service of the teachings of the Jewish law. In the introduction to Bar Ḥiyya’s *Ḥibbūr*, for one, he explicitly stressed as a main motivation, what he saw as the existing incompetence typical of many sages of his generation when it came to implementing the Jewish laws of inheritance that involved calculations of areas and division of patrimonies (Guttmann 1912-13, 3-4). One should keep in mind, however, that in many Hebrew texts of the time we find this kind of formulation used as a rhetorical device to justify the fact that a learned Jew is devoting his precious time and efforts away from the study of the Bible.

As Tony Lévy has stressed, we do not currently possess an accepted critical version of the Hebrew text of the *Ḥibbūr*. Nor has the issue of Bar-Ḥiyya’s sources been duly clarified. Still, it is remarkable that neither the term “algebra” nor the standard technical vocabulary normally used in the Islamic algebraic tradition appears in his text. On the other hand, the text does include much of the techniques for solving problems involving squares of the unknown and the kind of geometric justification that was standard since the time of al-Khwārizmī. Thus, it seems reasonable to assume that Bar-Ḥiyya knew well the relevant literature, but that he wanted to keep the technical vocabulary to a minimum so as to make his text easier for his intended readership to comprehend (Lévy 2001, 51-52). For the purposes of the present article it seems sufficient to put aside the textual difficulties that future scholarly work will have to further elucidate (Lévy 2001, 45-47), and to refer, without further comments,

to the Hebrew text published in 1912-13 in Berlin by Michael Guttman (1872-1942).²⁰

Bar-Ḥiyya's book has four main parts. In the first one we find a collection of geometric definitions and some elementary propositions relating to them. These are intended as providing the tools for what will be done in the following parts of the book. Most of the results presented in this section paraphrase results drawn from the *Elements*, including Book II, as we shall see right below. In the second part of the *Hibbūr*, Bar Ḥiyya discussed questions related to measurements of lands, buildings, and fields having all kinds of shapes: quadrilaterals, triangles, circles, and some more complicated others. This is, indeed, the most important part of the book. The third part deals with the division, into elementary figures, of those considered in the previous section. Finally, in the fourth part, Bar Ḥiyya extended some of the previously obtained results into volumes: prisms, cylinders, spheres, etc.

Given the main focus of interest of the book as developed in its second part, it is not at all surprising that Bar Ḥiyya mixed in a very conscious and purposeful way ideas taken from both geometry (חכמת השיעור) and arithmetic (חכמת המניין). Thus, while the first twenty definitions introduce basic geometric concepts, going from the point to the line (both of them following the Euclidean definition), and to the areas of various types of polygons, the following ones define the basic arithmetic concepts. The latter essentially repeat those of Euclid in the introduction to Book VII. This is the case, for

²⁰ The Hebrew printed version of Bar Ḥiyya's text is accompanied by an introduction in Hebrew written by Guttman and it contains further comments, also in Hebrew, written by Zvi Hirsch Yaffe (1853-1927). The Guttman edition also served as the basis for a translation of the text to Catalán (Millás Vallicrosa 1931).

instance, with BH-21²¹, where unit and number are defined: “The unit is that thing whereby each thing in the world is called – one. And number is a collection of a multitude of units”. But in some other cases, we also find minor, thought interesting differences that stress Bar Ḥiyya’s basic intention to apply these concepts in a framework that mixes the geometric with the arithmetic. Thus, while Euclid had used term such as “plane numbers”, “square numbers”, or “cube numbers”, in a rather metaphorical sense and while he never represented such numbers in his propositions other than as straight lines, Bar Ḥiyya, to the contrary, added to the corresponding definitions, a small diagram in the spirit of the Pythagorean figurate numbers. In this way, he prepared the ground for organically incorporating arithmetic into geometry. Thus, for instance, in the following two examples:

BH-22: And the number that is multiplied by another number is the number that is added to itself as many times as there are units in the second number in which it is multiplied, like two times three or two times ten and it is called a plane number and this is its shape $\begin{matrix} \cdot & \cdot & \cdot \\ \cdot & \cdot & \cdot \\ \cdot & \cdot & \cdot \end{matrix}$ and the number obtained by this addition is called a plane number.

BH-23: And a square number is a number obtained by adding a number to itself as many times as there are units in it, and the first number is called the root of the square (גדר המרובע). For example the number nine is called a square number because it is obtained from adding three to itself three times, and the number three is called the root of the square and this is its shape $\begin{matrix} \cdot & \cdot & \cdot \\ \cdot & \cdot & \cdot \\ \cdot & \cdot & \cdot \end{matrix}$.²²

²¹ The paragraphs are numerated in the edition I am using here. I add the initials BH, for ease of reference.

²² Read from the point of view of current Hebrew usage, Bar Ḥiyya’s terminology may give rise to some confusion, as was pointed out in (Sarfatti 1968, 82). I am following here Sarfatti’s interpretation (e.g., multiplication for “מנה”, addition for “כפל”, root for “גדר”). For a brief account

Bar Ḥiyya also defined a cubic number (מספר מעוקב), but not merely in a figurative manner, as one whose units can be arranged as a cube. Rather he defined it as “a body” (גוף) of equal length, breadth and height.

After this arithmetic preliminaries, Bar Ḥiyya moved without any clear separation, to work out several propositions which provide the main tools underlying the solutions for the problems discussed in the second section and in which arithmetic and geometric statements and arguments are freely mixed together. The connecting link is provided by a general comment, to the effect that the square of a segment is that figure built when another segment of the same length is set perpendicular to the given one and a square is thus built with four equal sides, while a rectangle is similarly built on two different segments. From here on, it is no problem to speak about geometric construction while associating numbers to the lengths of the segments. And this is indeed what Bar Ḥiyya did when presenting propositions II.4 to II.10 (but not including II.7), all of which deal with ways of dividing a segment into two parts and constructing squares or rectangles on the parts obtained (BH.27-BH.32). It is worth examining in some detail how he formulated and proved these propositions, while paying special attention to the unique combination of arithmetic and geometric ideas that he adopted.

Consider, for instance, BH-27, which corresponds to Euclid's II.4. Bar Ḥiyya speaks here about a line that is divided at an arbitrary point and about the squares that are built on the resulting segments. But to this purely geometric formulation he added: “and I give you an example with numbers” (ואני נותן לך בזה דמיון מן המניין), which in this

of the differences between ancient and modern Hebrew mathematical terminology see (Corry & Schappacher 2010, 449-457).

case is a line of length 12 divided into two segments of length 7 and 5. We can look more closely at the specific roles that Bar Ḥiyya assigned to geometry and to arithmetic in his presentation, by examining in closer detail what he does in the proposition corresponding to II.9 (BH-31). Let us first look at the proof as it appears in the text and then I will comment on it.

The proposition is formulated in the standard Euclidean way and it is also exemplified by a line of length 12 which is divided at its mid-point and at another point into segments of lengths 7 and 5.²³ Two squares taken together, one of side 7 and one of side 5, make 74. And on the other hand duplicating the square with side 6 and the square with side 1 (1 being the difference between the half, 6, and the long segment, 7) also makes 74. Having introduced this numerical example, Bar Ḥiyya moved to the proof, which interestingly differs from Euclid's, which – as seen above – relies in a non-trivial way on the Pythagorean theorem. Bar Ḥiyya's own wording is quite contrived but it is worth being presented here (with some simplification). Below I will streamline his argument with the help of diagrams, which will make it easier for the reader to capture the main idea.

Take the line AB , of length 12, and divide it in its half at E , and also into two different segments, of length 7 and 5, at I .

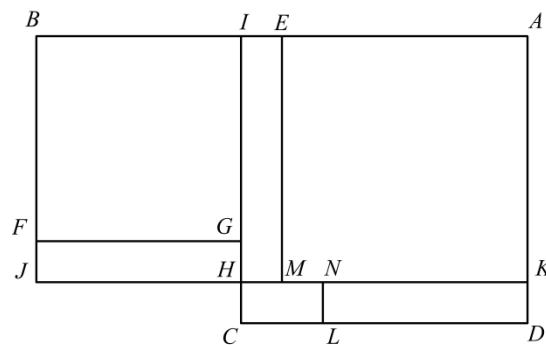

²³ Actually the text in Gutmann 1912-13, p. 15, says: “על 4 ועל 5” (on 4 and on 5). But this seems to be a typo.

Figure 20

Construct $AICD$ being 7 on 7, and $BIGF$ being 5 on 5. Taken together, says Bar Hiyya, these two squares equal the sum of $AEMK$ and $EMJB$ (which is the same as taking twice the square on the half, that is twice 6 on 6), together with $HNLC$ (which is twice the square of the difference, that is 1 on 2). And why this is so? Because – tells us Bar Hiyya – $FGHJ$ is placed under $BIGF$ and on the same line with the square of half the segment, $AEMK$.²⁴ And we count it in this way together with square $AICD$. Thus, both $FGHJ$ and $NKDL$ are like 5 on 1. And the reason for this is that AKD equals AEI and both are 7 and on the other hand AK equals AE which is 6, and hence what is left is KD which equals IE which is 1. But also DLC equals AEI and if one subtracts CL which is 2, then one is left with LD which is 5. Hence $NKDL$ is 1 on 5 and the same is true for $FGHJ$ because MJ equals EIB which is 6, and the line BF equals BI and we are left with FJ and IE which are 1, and the length of JH equals that of BI . Here ends Bar Hiyya's proof.

Now, just from this more or less literal transcription of the proof, we can already learn much about Bar Hiyya's overall approach. In the first place, in spite of his insistence in repeating the numerical values of the segments at various places along the proof, these values play no role whatsoever in the argument and they are never arithmetically manipulated in order to get any result. Rather, they only accompany the steps of an argument that fully relies on completing a geometric construction and on learning from looking at this construction. Indeed, the geometric construction is quite simple and what is said about it does not go beyond basic "cut and paste" considerations. But in addition, since Bar Hiyya's wording for this particular

²⁴ (Guttmann 1912-13, 15) [In the quotation I have replaced the Hebrew letters appearing in the original diagram with the letters I am using here in my diagram]:

“מפני שמרובע $FGHJ$ העודף על מרובע חלק הקטן $BIGF$ והוא נמצא עם מרובע מחצית הקו האחד $AEMK$ והוא נמנה עם מרובע חלק הגדול והוא $AICD$ בצורה הזו.”

proposition is so contrived (this is much less the case for other propositions in this section), one may even speculate that without introducing here the numerical values of the lengths Bar Ḥiyya may have had some difficulty in working out the argument even for himself. More certainly, he may have thought that his readers would find the argument easier to follow in this way, and in any case, in the later sections of the treatise, he would be using the result only in its arithmetic version.

But it is also important to notice that, perhaps because of the didactical character of this treatise, Bar Ḥiyya often relied on the diagrams in a stronger sense. That is: in constructing the figures that appear in the diagrams of many of his proofs, he left *implicit* several facts that he nevertheless used as part of the argument. The facts have to be inferred from the diagram while following the steps of the proof. Thus, in the case we are examining here, the diagram shows – but Bar Ḥiyya does not say so – that $AK = BJ = AE$, and hence HC equals IE . Also, part of the construction, as we learn only from the proof itself, is that HN equals twice IE .

Keeping these general remarks in mind, we can now reformulate the core of the proof by looking at the diagrams and reasoning with them.

With reference to the diagram, what we are asked to prove is just:

$$AICD + BIGF = 2 \cdot \text{Sq}(AE) + 2 \cdot \text{Sq}(IE).$$

Bar Ḥiyya tells us that in his construction “ CL is 2”, and this means that $HMN = 2 \cdot IE$, and hence $HNLC = 2 \cdot \text{Sq}(IE)$. Thus, all what remains to be shown is that $NKDL = FGHI$. And this is true, he says, because the long side of both rectangles equals BI , while their shorter sides equal IE . Let us see why this is so, starting with the short sides, KD and FJ , and stating the idea in purely geometric terms:

(g.1) By construction $AKD = AEI$ and $AK = AE$, hence $AKD - AK = AEI - AE$,

hence $KD = IE$

(g.2) Again by construction $JHM = EIB$ and $BF = BI$. But $BI = FG = JH$, hence
 $JHM - JH = EIB - BI$, hence $FJ = IE$.

(g.3) Hence [from (i.1) and (i.2)]: $KD = FJ$.

And now I give the argument for the long sides, HJ and LD , using numerical values as Bar Ḥiyya's did, because in the last step one sees that, although there is nothing here but a simple geometric situation that holds true independently of the values, explaining it with the numerical values really makes it easier to follow:

(g.4) By construction $HD = BI$ (and both are 5 – this is left implicit using the fact that “ $FGHJ$ is placed under $BIGF$ ”).

(g.5) $DLC = AEI$ and if one subtracts “ CL which is 2”, then “one is left with LD which is 5”.

“ CL is 2” means, of course, that CL was built as twice the difference between the longer segment and the half of the given segment, even though this was not explicitly stated. But explaining the situation in these more abstract terms would make the argument longer, and apparently Bar Ḥiyya was happy with being able to make it shorter and easier to follow with the help of the numerical values.

Notice that the main tool on which the proof rely (and this is true for various other proofs as well) is the distributivity of the product (or, more precisely, of rectangle formation), which as we know are embodied in II.1-II.3. Bar Ḥiyya applied freely this property without in any way discussing it or even mentioning in the text.

Bar Ḥiyya completed the first part of his book by discussing (in BH-33 to BH-41)

various propositions taken mostly from the *Elements*,²⁵ and which deal with properties of circles, triangles and other figures. And as already stated, part one is actually intended as providing tools for solving numerical problems involving an unknown quantity. Hence, I complete now this overview of Bar Ḥiyya's text by showing an example of solving a quadratic equation (in BH-49) while using II.5 for justifying the procedure used. The problem is the following: “if the square is subtracted from four times the side the result is three” (מרובע השלכת תשברתו מן מנין) (ארבע צלעותיו ונשאר בידך שלשה).

The solution is found by following a simple procedure: half the number of sides is 2 whose square is 4. Subtract from this the remainder three and you obtain one, whose square is one. Subtract this result from half the sides and you are left with one, and this is the side of the square, or add the result to half the sides and you get 3 which is also the side of the square. The side may be one or it may be 3, “because there are two different calculations for this question”.²⁶

As in the Islamic tradition, Bar Ḥiyya also presented geometric “proofs” for justifying the procedure used in solving the problem. It is worth seeing here some of the details of this proof, that are highly reminiscent of Thābit ibn Qurra.

The proof is better understood by reference to the two figures that accompany the text, of which the following is the first one (הצורה הראשונה):

²⁵ These include, in the order in which they appear, versions of: III.35, I.33, VI.4, I.37, I.38, I.41, I.35, I.36 and VI.1.

²⁶ In §49: “כי שני חשבונות לשאלה הזאת”. In the text Bar Ḥiyya sometimes calls the number by its name and sometimes uses the alphabetic characters ... א, ב, ג, to indicate them. For the side of the square or for the unknown Bar Ḥiyya uses alternatively גדר and צלע, even within the same sentence. The text has many interesting linguistic aspects that I do not discuss here, starting with the very use of the word “thisboreth” (תשבורת).

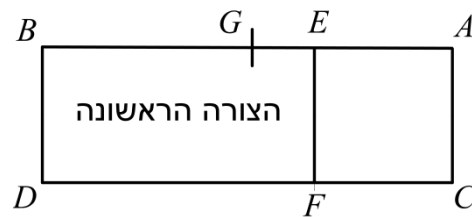

Figure 21

In this figure, AB is taken to be four “amoth” (אמות), the “coefficient” of “sides” in the problem, whereas AC is the “side” of the square referred to in the problem.

The argument then goes as follows:

- (h.1) Subtract from the parallelogram $ACDB$ a square $ACFE$; the remaining parallelogram $EFDB$ is three amoth, [this is actually the statement of the problem]
- (h.2) Cut now AB into two equal parts at G ; since E divides AB into two unequal parts, it follows that the parallelogram on AE , EB together with the square on EG equals the square on AG , [this is II.5]
- (h.3) But we know that the square on AG is 4 [since G cuts AB in its middle point], and if we subtract from it the parallelogram on AE , EB (namely, $EFDB$) which is 3, then we are left with 1, and this is the value of the square on EG ,
- (h.4) Hence EG is one, and, since AG is two, EA is one, and this is the side that we are looking for.

As part of the same proof, Bar Ḥiyya also indicated how the second solution is justified by reference to a second diagram (הצורה שנית):

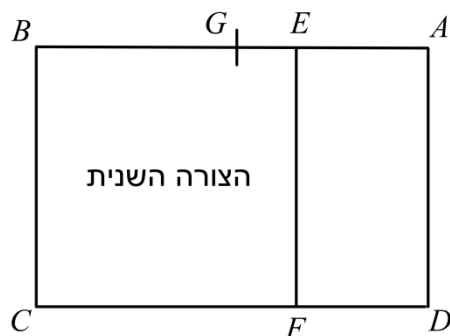

Figure 22

The argument is similar to that of the first part, and we need not go here into all the details.

This problem is similar to Abū Kāmil’s treatment of “square and numbers equal roots of the same square”. Also Abū Kāmil justified the procedure for solving this case with the help of II.5 and he accompanied his explanations with two diagrams similar to those of Bar Ḥiyya here. Curiously, however, Bar Ḥiyya presented his problem by *subtracting* the square, thus departing from the practice followed in Islamic texts (to state it in modern algebraic terms: Abū Kāmil used the typical formulation, $x^2+b=ax$, whereas Bar Ḥiyya formulated the problem as: $ax-x^2=b$). And, as did Abū Kāmil, Bar Ḥiyya indicated two solutions for the problem.

Bar Ḥiyya’s explicit and implicit references to results originating in Book II provide us with an illuminating, direct insight into one specific (and perhaps rather idiosyncratic) way in which a reader with a significant knowledge of Islamic techniques of problem solving could read Euclid from an arithmetic and proto-algebraic perspective. Bar Ḥiyya understood the propositions of Book II as both an expression of properties of numbers and as the proper way to provide legitimation for algebraic techniques of problem solving. But he continued to read these propositions

as ultimately based on geometric reasoning, even when he thought it convenient, possible on didactical considerations, to accompany with numbers the text where he described this pure geometrical reasoning. Products were seen here as square- or rectangle-formation, and the proofs were based on geometric properties of these figures.

The readership of Bar Ḥiyya's Hebrew text, of course, was rather limited, and it thus had little direct impact on the wider Latin medieval mathematical culture in Europe. Nevertheless, as already indicated, the text also appeared in 1145 in a Latin version commonly attributed to Plato of Tivoli which did have an important impact, mainly through the work of Fibonacci. As Tony Lévy has indicated, one may conjecture that in preparing the text, Plato worked with some Jewish collaborator, possibly (but by no means certainly) Bar-Ḥiyya himself (Lévy 2001, 53-55). The Latin version, at any rate, is not just a mere transcription, and it differs from the Hebrew text in various senses (omissions, additions, reformulations, etc.). Of interest here are some differences pertaining to the interplay between geometry and arithmetic.²⁷

Such differences appear, for instance, in the first part of the text. The Latin version contains no diagrams at all in this part, contrary to what is the case in the Hebrew one, but on the other hand, it follows much more closely the structure and wording of Euclid's Book I. Indeed, here as in other parts of the text, results from the Books I-IV which are introduced without proof and which are necessary for proving other results, are clearly not directly translated from Bar Ḥiyya. Tony Lévy (2001, 54; note 3) has suggested that they were taken from an Arabic version of the *Elements*, possibly of the more ancient ones associated with Hajjaj.

²⁷ Like with the Hebrew text, also here there are some open issues concerning the manuscripts. See (Curtze 1902, 4).

As an example of the difference between Plato and the original text of Bar Ḥiyya, we can notice that the latter introduced parallel lines (הקוים הנכוחיים) quite early in the section, and that he gave in the same paragraph two different definitions, namely, as equidistant lines (i.e., as such lines that “the distance between them is constant also when they are extended”) and as lines that do not intersect if extended infinitely (לא יִפְגְּעוּ). In the Latin version, in contrast, the definition appears at the end of the preliminary section (Curtze 1902, 15, BH-28), and exactly as in Euclid: these are lines that, while laying on the same plane, do not meet which each other when produced infinitely (*ad infinitum*).

After the preliminary definitions, we find in the Latin version the five Euclidean postulates and a list of common notions. None of this appears in the Hebrew text. The common notions are not just the five Euclidean ones, but also some additional ones, such as “two things which are the double of the same thing are equal to each other”, and the same for the half, or “a thing is the sum of its parts” and “two lines contain no area” (Curtze 1902, 15-17). Another important difference concerns the basic definitions of numbers and their properties, which in the Latin version basically repeat those appearing at the beginning of Book VII. At the same time, definitions such as BH-21,22 of the Hebrew version (see above) are absent from the Latin text.

In the Latin version, the propositions of Book II are only formulated and not proved, “since they were already proved by Euclid” (p. 19). Still, the geometric formulation of each proposition is followed by a numerical example. On the other hand, it is interesting to notice that in the second part of the treatise, the problems solved with the help of the propositions of Book II, are essentially a verbatim translation of the Hebrew original.

One can only speculate about the reasons for differences between these two versions, and to attribute them to the different audiences and different purposes against the background of which they were conceived. One may also hope for new, critical edition of Bar Hiyya's text on the question of the complex relationships between the Hebrew and the Latin texts.

6.2. Liber Mahameleth

Liber Mahameleth is a text on commercial arithmetic, presumably written in or near Toledo around 1143-1153. Anne-Marie Vlasschaert, who recently published a critical edition (Vlasschaert 2012), has suggested that Dominicus Gundisalvi (c. 1110-1181), or someone in his school of translators, may have been the author. The text bears some relation to an earlier Arabic text likely called *Kitab al-mu'amalat* ("Book of Transactions"). Most likely, however, *Liber Mahameleth* is not a direct translation from the Arabic but rather a new work written in Latin in the context of the scholarly culture of Al-Andalus.

The author evidently had a good command of Euclid's *Elements* and of Abū Kāmil's *Algebra*, and he constantly relied on their results within his own proofs. *Liber Mahameleth* can be seen as an attempt to provide a comprehensive synthesis of important contributions of these authors, as well as of Nicomachus, al-Khwārizmī, and some other classical Greek and Arabic authors. This synthesis, moreover, was specifically oriented towards providing a practical compendium of arithmetical tools, grounded on a systematically discussed theoretical basis for the basic operations, particularly those involving fractions and fractions of fractions. The core of the text deals with applications of these operations to problems related to commercial

transactions, such as prices, profit sharing, consumption of oil by lamps, of feed by animals or of bread by humans, etc., as well as of problems of a more theoretical kind.

The first ten propositions of Book II of the *Elements* appear prominently in the preliminary, theoretical section of *Liber Mahameleth*. Clearly influenced by Abū Kāmil, the author certainly went much further than him in positioning these propositions in a foundational role for arithmetic, and in explicitly stressing their indispensability for any prospective reader of the book. Indeed, the author stated that he was reformulating what in Euclid, are propositions on “segments”, and that he was rephrasing them now for “numbers” (p. 25). Still, on closer examination and in spite of this stated intention, most of the proofs provided for propositions taken from Book II retain a distinct geometric flavor. This can be seen, for instance, in relation with the proof for II.5 (p.28), which essentially repeats Heron’s cut-and-paste argument. As we saw, Heron operated upon areas of rectangles and squares (i.e., first separating them into components and then reassembling), and also here, in *Liber Mahameleth*, the argument explicitly relies on applying distributivity of rectangle-formation over addition, such as embodied in the corresponding versions for II.2-II.3 (pp. 26-27). Also the accompanying diagram is similar to Heron’s:

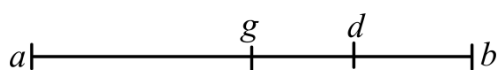

Figure 23

Again as with Heron, we do not find here actual geometric constructions made on the segments, but squares and rectangles are indeed implicitly constructed as part of the reasoning. In all respects, the proof qualifies as “geometric” in the sense that I have been using here, and in none of the steps there is anything like counting units comprised by any of the numbers involved.

What is of special interest in *Liber Mahameleth* in relation with Book II is that in laying down the foundational aspects of arithmetic, the author combined this kind of propositions and proofs with others that are purely arithmetic, thus giving rise to an original blend of approaches, in which distributivity of the product was assigned a pivotal role. Proposition 9 of the preliminary section (pp. 25-26), which is parallel to Euclid's II.1, plays an important role in the presentation. Its proof is worthy of special attention, because it is based neither on geometric nor on arithmetic considerations, but rather on properties of proportions drawn from Books V and VII. I discuss this in greater detail in [LC2].

It is also pertinent to see how the propositions appearing in the preliminary section of *Liber Mahameleth* are then used to justify procedures for problem solving in the main body of the book. Thus, for instance in the following example which uses a version of II.6 (pp. 410-411):

A ladder of unknown length is leaning on a wall, and it is withdrawn from its bottom by a distance that, when the descent from the top is subtracted from it, the remainder is 4, and if we multiply those two lengths the result is 12. What is the length of the ladder?²⁸

The situation is represented in the following diagram:

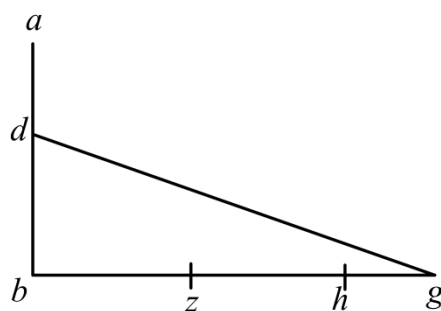

²⁸ A detailed analysis of this problem and its roots in Babylonian mathematics appears in (Sesiano 1987).

Figure 24

The proof starts with the data of the problem, namely, $ad \cdot bg = 12$ and $bg - ad = 4$. Now, the length hg is cut from bg , so that $hg = ad$. Hence, $bh = 4$. But also $bg \cdot hg = 12$ (since $hg = ad$). Finally, the point z bisects bh (i.e., $hz = 2$). Here we can apply II.6 (“*sicut euclides dixit*”) and we obtain: $bg \cdot hg + hz^2 = zg^2$. Thus, clearly, $zg = 4$, and consequently also $bg = 6$. Finally, $ad = 2$.

This is certainly not an example of an application of the propositions of Book II to a “real-life problem”, but what really concerns our discussion here is how the author of *Liber Mahameleth*, also in this more applied part of the text, combined the arithmetic and geometric ideas discussed in the preliminary section. Very much like the “didactical” approaches followed in the contemporary versions of the *Elements* we find here continual cross-references between the two realms without the author emphasizing the possible differences. This creates a somewhat ambiguous but very interesting situation. Indeed, notice that in my rendering of the proof above I wrote the products as arithmetic, not geometric operations. Thus, for instance, I used II.6 as $bg \cdot hg + hz^2 = zg^2$, rather than as I did with all previous authors, $R(bg, hg) + Sq(hz) = Sq(zg)$. There were actually good reasons to choose the geometric rendering. For one thing, the entire situation is embodied in a diagram. For another thing, the wording for the product here is exactly the same as that used for rectangle-formation in the first part of the treatise (“*Quod igitur fit ex ductu bg in hg et hz in se equum est ei quod fit ex ductu zg in se*”). Indeed, it is precisely this same wording which allows the use of the theoretical results proved in the first part for handling specific problems appearing in the second. Nevertheless, the choice of arithmetic rendering, was guided by what seems to have been the author’s own view, namely that he was dealing in this part with numbers. But the choice could have been in either direction, precisely in view of

the very elusive and ambiguous attitude of the author towards what is geometric and what is arithmetic in his treatment. Thus, while the propositions of Book II are incorporated in *Liber Mahameleth* into an arithmetic framework, the essentially geometric conception of the meaning of these propositions is still very pervasive both in the first, theoretical part of the treatise, and in the second, more practical one. In particular, it is clear that the arithmetic ideas developed here do not in any way embody any kind of algebraic implications.

6.3. Fibonacci

Leonardo Pisano Fibonacci (c. 1170 – c. 1250) is widely considered to be the most prominent and emblematic figure in medieval European mathematics. He was well acquainted with Greek, Byzantine, and Arabic sources, and played a key role in compiling and helping disseminate in Western Europe innovative mathematical techniques and concepts, particularly the use of the Hindu–Arabic system of numeration and methods for solving equations. Fibonacci produced several works that reached relatively broad audiences and in which he combined theoretical aspects with very practical tools for land measurement and commercial calculations (Archibald 1913; Folkerts 2004). In fact, he promoted a new kind of scientific genre, the “*practicae*.” These were brief works, written in a popular style intended for lay readers, and with a clear emphasis on applications (Hughes 2008, xvii–xxxv; Simi 2004).

It is not completely certain what version of the *Elements* was available to Fibonacci. He may have simultaneously relied on several of the existing translations, including the one made directly from Greek (Folkerts 2004, 109–110; Hughes 2008, xix). At

any rate, there is no doubt that Fibonacci was well-acquainted with Euclid's text and that he mastered all the techniques taught there. This is certainly the case for Book II, whose propositions he cited and used explicitly as the geometric justification for the problem-solving techniques that he borrowed from Islamic sources. But it seems that it was the *Liber Embadorum*, Plato of Tivoli's Latin version of Bar Ḥiyya, which exerted the most influence on Fibonacci, particularly as manifest in *De Practica Geometrie*, discussed below. Curiously, Fibonacci did not explicitly mention Bar Ḥiyya as Plato's source, perhaps because he considered the name Savasorda as a title, rather than as a patronymic that might help identify the author (Hughes 2008, xxiii-xxiv). Influential for him was also the work on algebra of Abū Kāmil, which he may have known either directly or indirectly.

Fibonacci's specific use of the propositions of Book II appears in *Liber Abaci* and in *De Practica Geometrie*. *Liber Abaci* appeared first in 1202 and then in a second edition in 1228. This is perhaps the best known of Fibonacci's books and the main one through which his influence was felt over the next centuries in Europe, particularly in what concerns the development of techniques for calculating and operating with square and cubic roots, and for solving numerical problems. In Chapter 14, Fibonacci presented some formulas or "keys" (*claves*), of fundamental importance for the techniques taught in the book, comprising results "which are clearly demonstrated in Euclid's second book." As the author of *Liber Embadorum*, Fibonacci did not provide geometric formulations for these results, but just numerical examples. Of special importance were those propositions corresponding to II.5 and II.6, since to them, Fibonacci explicitly wrote, "are reduced all the problems in *algebra almuchabala*" (Sigler 2002, 490). It is surely relevant for us, then, to take examine how Fibonacci used these results within a book of arithmetical content. But

in order to grasp the context properly, it is helpful to first add some general comments about the book.

Geometric considerations appear in the book only after thirteen chapters of detailed explanations about the decimal system and its uses for calculating and for solving all kinds of numerical problems (but with nothing like symbolic notation or manipulation). Still, it is clear that for Fibonacci such considerations were crucial from a theoretical point of view because only the geometric interpretation could provide the correct setting for handling surds. Thus, “according to geometry, and not arithmetic, the measure of any root of any number is found” (Sigler 2002, 491). Fibonacci explicitly presented a procedure for finding such root: if you want to find the root of 10, for example, you need to find two numbers that multiplied together make 10, say 2 and 5. You add them together and obtain 7, and “you will order this to be the measure of the line”. This is done by arranging measured segments as in the following diagram:

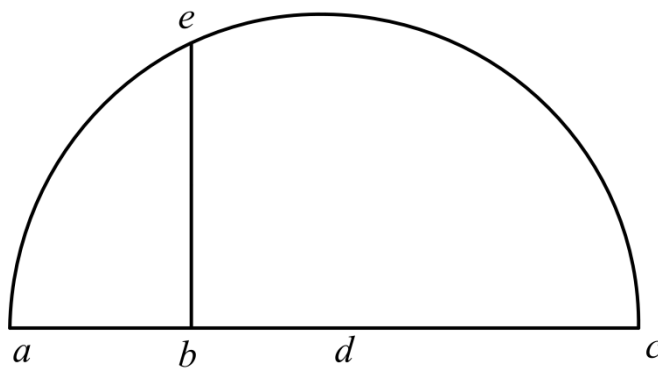

Figure 25

Here ab represents 2, and bc represents 5, and the circle is traced around the midpoint d , and eb is the perpendicular drawn on b . This segment is the root of 10, “as is clearly shown in geometry”.

Fibonacci’s attitude towards the results of Book II was along these lines. He did not

derive these results geometrically, and he continued to use, in the last chapters of the book, a purely arithmetic language wherever the problems or the calculations involved allowed for it. But he made it clear, in places where he relied on results of Book II, that it is their origin in geometry that makes them useful as a source of legitimacy for the arithmetic knowledge presented. The main place where this is done is in a section devoted to the “Solution of Certain Problems According to the Method of Algebra and Almuchabala, Namely Proportion and Restoration”. The cases treated by Fibonacci are parallel to the six cases of al-Khwārizmī. He presented them by combining numerical examples, a formulation of the general rule (in purely rhetorical manner), and a geometric justification of the procedure. Where necessary, Fibonacci used the Euclidean results that he had already introduced, but without explicitly invoking them each time. I illustrate this with the example of the case “census plus a number will equal a number of roots”.

This case can be solved only if the number is equal or less than the square of half of the roots, and if this is so, then the solution is obtained as follows (Stigler 2002, 557):

[If] it is equal, then half of the number of roots is had for the roots of the census, and if the number which with the census is equal to the number of roots is less than the square of half of the number of roots then you subtract the number from the square, and that which will remain you subtract from half the number of roots; and if that which will remain will not be the root of the sought census, then you add that which you subtracted to the number from which you subtracted, and you will have the sought census.

In the numerical example Fibonacci considered the question “the census plus 40 be equal to 14 roots”. This is of course, the same case we met in Bar Ḥiyya’s book,

but formulated without using subtraction and of course using different numerical values. This case leads, as we know, to two possible solutions (by subtracting or adding the said square root), namely, either 4 or 10. Fibonacci implied that for a given problem only one of these values will be the solution sought (the problems come later). What interests us here is, of course, how this procedure is justified with the help of II.5, and this is seen by referring to the figure that accompanies the text, which is the following:

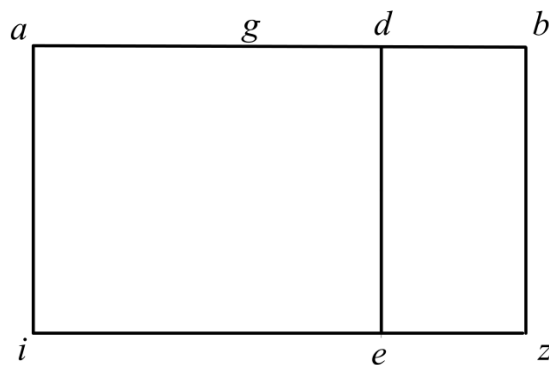

Figure 26

Schematically, the steps of the argument are the following:

- (i.1) Take ab to be 14, and bisect ab at g . Also the point d cuts ab , and we build a square dz , which is the census referred to in the problem.
- (i.2) The segment zi is traced equal in length to ab . Since zb is “the root of the census dz ” and since ab is 14, hence az , the entire area, is 14 roots of the census, and hence the area ae is 40, as stipulated in the problem.
- (i.3) Now ae is ad times de , or, ad times db [remember, dz is a square]. It is here that II.5 can be applied: $ae = R(ad, db) + Sq(gd) = Sq(gb)$.
- (i.4) But gb is 7, as it is half of ab , and its square is 49. Hence, as ae is 40, it follows that the square on gd is 9, gd is 3, and db is 4, and this is the root of the sought census.

A slight variation in the argument and the figure leads to the second solution, 10.

This proof is essentially the one already seen in Bar Ḥiyya's text.

Notice that I used here the notation $R(,)$ and $Sq()$, only in step (i.3). This seems to me to reflect the way Fibonacci conceived the argument, namely, an argument basically on numbers, which at a certain points invokes a geometric result taken from Book II, in order to reach the correct solution.

Again, to put things in the right context, it must be stressed that the section that presents the six cases of solving quadratic equations (and where the above discussion appears) is a relatively brief one. But the techniques introduced in this section are subsequently used in the remaining chapters of the book, where Fibonacci discussed a long series of specific arithmetic problems and showed how to solve them using the techniques previously taught. Thus, we see how in *Liber Abaci*, a book which is devoted to presenting a broad panorama of arithmetic and its applications, Book II is used as a source of certain, geometric knowledge that is still needed for providing a sound justification of the methods presented.

The second book of Fibonacci that interests us here is *De Practica Geometriae*, composed in 1220 or 1221, between the two editions of the *Liber Abaci*. In many respects the treatment of square and cubic roots, the references to Book II, and the possible use of its propositions for solving problems involving squares of unknowns are all quite similar to those of the *Liber Abaci*. But one important difference between the two books is found in an entire section of the *Practica* where Fibonacci cited twelve propositions from Euclid's *Elements*, the first nine of them being versions of propositions in Book II (II.8 is absent). He also provided proofs for some of these propositions which differ interestingly from Euclid's or Heron's. It is of interest for

us here to see the details of at least one of these proofs, and I will focus on II.9.²⁹

Proposition PG-38 corresponds to II.9 and the accompanying diagram is the following (Hughes 2008, 30):

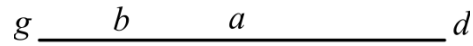

Figure 27

The line gd is divided into equal parts at point a and into unequal parts at point b , and the proposition states that the squares on gb and on bd are twice the two squares on da and on ab . The proof goes as follows:

Since line ag was bisected at point b , the two squares on lines bg and ba with twice the product of ab by bg equal the square on line ga , that is, the square on line ad . Now the square on line ba with just one product of ba by bg equals ba by ag . Whence the square bg with the product of ba by ag and with that of ba by bg equals the square on line ad . Let the square on line ba be commonly adjoined. Then the two squares gb and ba with the products of ba by ga and ba by bg are equal to the squares on lines ad and ab . But the square on line ba with the product of ab by bg is as the product of ba by ag . Therefore the square gb with twice the product of ba by ga is equal to the two squared lines da and ab . When the square on line da with the square on line ab exceeds the square on line gb by twice the product of line ba by ga ; that is, ba by ad . Likewise, because line bd was bisected at point a , the squares on lines da and ab with twice the product of ba by ad equal the tetragon or square on line bd . Therefore tetragon bd exceeds tetragons da and ab by twice the product of ba by ad . Therefore, by as much as tetragons da and ab exceed the tetragon bg , by so much are they exceeded by tetragon bd . Whence tetragons gb and bd are twice the squares da and ab .

Interpreting the steps of the proof (particularly the last one) directly from the text is far from evident, so I render it schematically. What we get is the following:

²⁹ It would also be of particular interest to compare Fibonacci's proof of II.5 with all the others discussed here, but in consideration with the length of this article I will focus on II.9 alone.

(j.1) Since $ga = gb + ba$ and $ga = ad$: $Sq(ad) = Sq(ga) = Sq(gb) + SQ(ba) + 2 \times R(gb, ba)$

(j.2) But, by construction, $R(ga, ba) = Sq(ba) + R(gb, ba)$

(j.3) Hence $Sq(ad) = Sq(gb) + R(ga, ba) + R(gb, ba)$

(j.4) Now, $Sq(ad) + Sq(ba) = Sq(gb) + R(ga, ba) + R(gb, ba) + Sq(ba)$

(j.5) Hence [by (j.2)], $Sq(ad) + Sq(ba) = Sq(gb) + 2 \cdot R(ga, ba)$

(j.6) Or, equivalently: $Sq(ad) + Sq(ba) = Sq(gb) + 2 \cdot R(ad, ba)$

(j.7) Now, since $bd = ba + ad$: $Sq(bd) = Sq(ad) + SQ(ba) + 2 \cdot R(ad, ba)$

(j.8) Hence [from (j.6) and (j.7)]: $Sq(bd) + Sq(gb) = 2 \cdot [Sq(ad) + Sq(ba)]$

Q.E.D.

The conclusion in (j.8) is not transparent, and interpreting it with the help of diagrams makes it easier. This can be done as follows:

Steps (j.1) – (j.3):

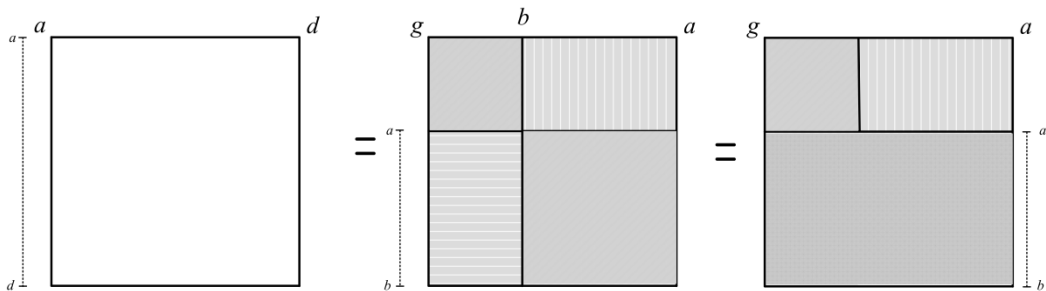

Step (j.4):

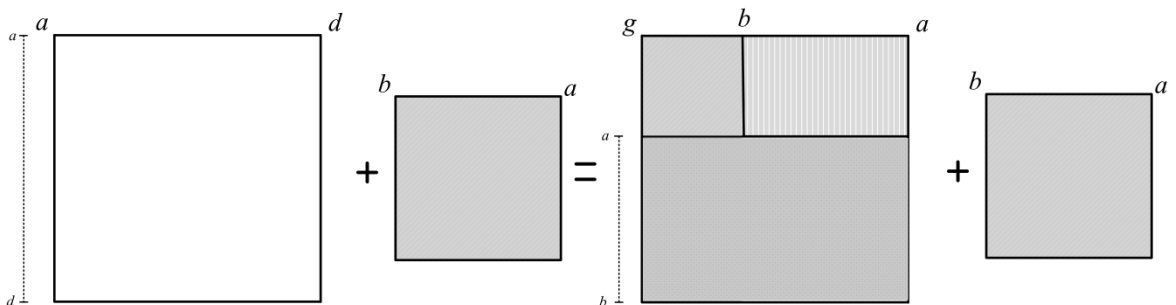

Steps (j.5)–(j.6):

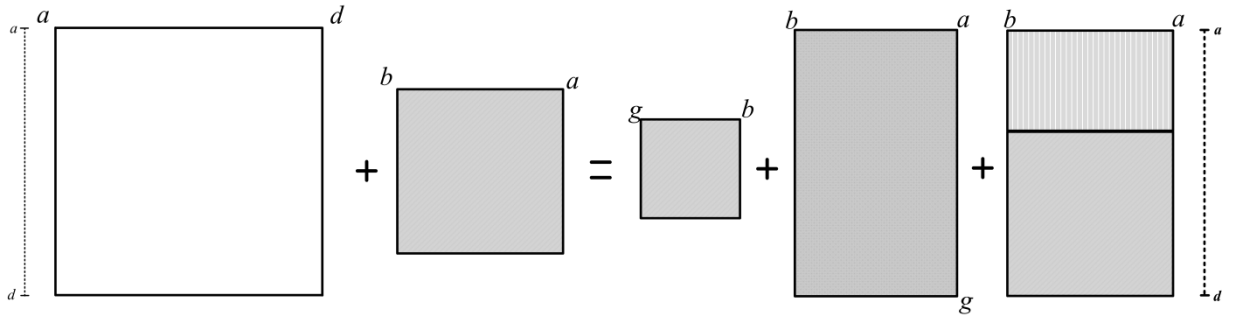

Step (j.7):

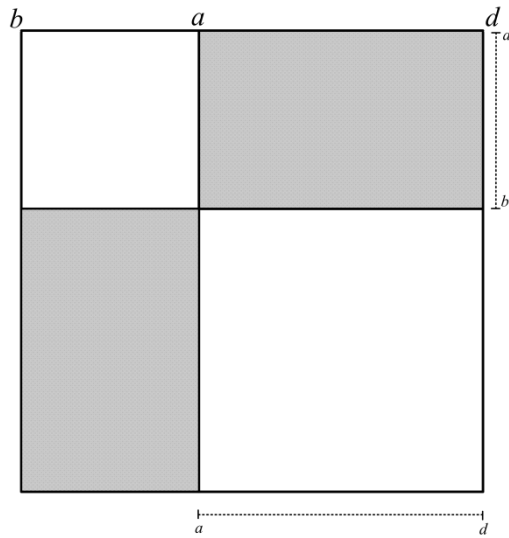

Finally, step (j.8), combining (j.6) and (j.7):

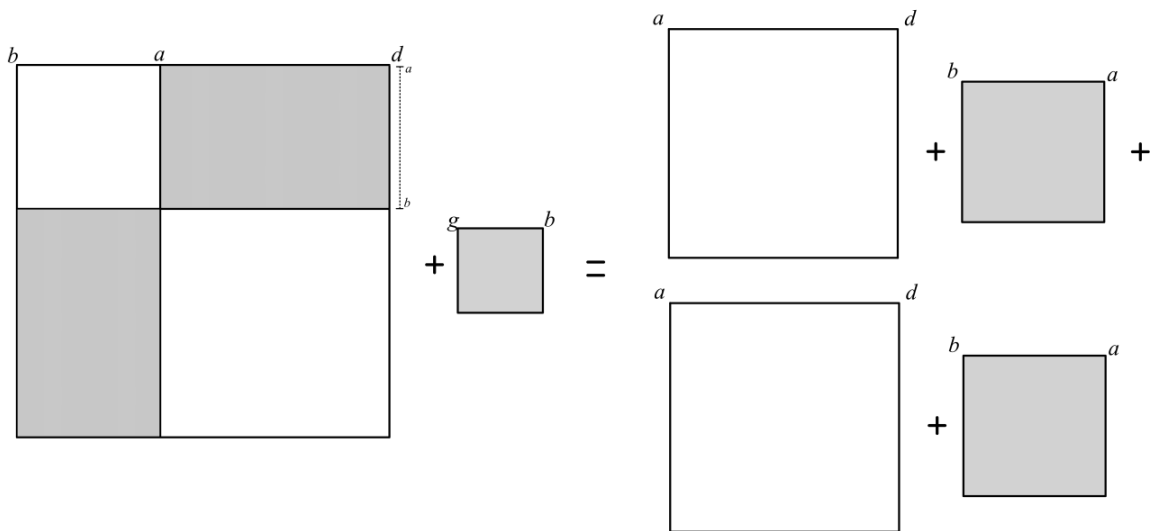

Figure 28

If these diagrams do not really clarify how (j.8) actually follows from (j.6) and (j.7), we can further try to explain this argument by operating, in a proto-algebraic manner, with the various figures involved. Indeed, what Fibonacci says is that: “by as much as tetragons da and ab exceed the tetragon bg , by so much are they exceeded by tetragon bd . Whence tetragons gb and bd are twice the squares da and ab ”. Schematically, this is:

$$\text{Sq}(ad) + \text{Sq}(ba) = \text{Sq}(gb) + 2 \cdot R(ad,ba) \quad \text{Sq}(bd) = \text{Sq}(ad) + \text{Sq}(ba) + 2 \cdot R(ad,ba)$$

And if we now subtract term by term the second identity from the first, we obtain

$$[\text{Sq}(ad) + \text{Sq}(ba)] - \text{Sq}(bd) = \text{Sq}(gb) - [\text{Sq}(ad) + \text{Sq}(ba)].$$

Hence:

$$2 \cdot [\text{Sq}(ad) + \text{Sq}(ba)] = \text{Sq}(gb) + \text{Sq}(bd)$$

as requested.

What has actually Fibonacci done here? As in the *Liber Abaci*, Fibonacci is building the legitimacy of his arithmetical techniques by reliance upon geometric results, and by stressing the geometric character of the underlying arguments. But rather than presenting the standard Euclidean proofs for those results taken from Book II, he has preferred to introduce his own, new kinds of arguments. The latter lack the transparency and simplicity characteristic of the Euclidean original, and they are also less straightforward than Heron’s, whose operational approach Fibonacci essentially follows. But the underlying line of thought is a rather innovative and original one. Indeed, Fibonacci has tried to incorporate into his geometric proofs techniques, or at least patterns of thought, derived from the “*algebra almuchabala*” that he had come to master so well. This is most clearly evident in step (j.8) above, and the way it was derived from (j.6)-(j.7), as just explained. The kind of “balancing of an equation” that helps understand the derivation is indeed the kind of “balance and compensation”

technique introduced in Islamic mathematics to reduce any given problem to the standard, known ones. In this case Fibonacci did not have an equation in the sense of an expression with abstract symbols that could be operated upon, but he did have the a situation similar to that found in the texts of Islam algebra, which rhetorically expressed relations between numbers, unknown quantities and their squares, and he used the techniques of “*algebra almuchabala*” to simplify these expressions. Notice, moreover, that also some other steps followed in the two proofs described above seem more easily understood from this perspective. Thus for instance, (j.4)-(j.5) find a more natural place in the arguments once we have conceded that Fibonacci followed techniques of “*algebra almuchabala*” as part of his derivations.

It should be noticed that also the distributivity afforded by II.1 (or its direct derivatives, such as II.2-II.3) is crucial for all the arguments presented in *De Practica Geometriae*. I discuss this point in some detail in [LC2].

This survey of the ideas of Book II as they appear in the works of Fibonacci affords a further, interesting perspective on the rather original and divergent ways in which those ideas could be handled in medieval mathematical treatises. Basically, Fibonacci continued to see in geometry a source of certainty which could account for situations where arithmetic appeared as insufficiently clear. At the same time, however, his way of using geometric results on behalf of arithmetic was far from uniform. He either took some of the results for granted, or just illustrated them with numerical examples, or introduced new proofs for the Euclidean results in which he tried an innovative, proto-algebraic reasoning as part of the argument. This many-sided and rather flexible view of the relationship between geometry, arithmetic and algebra certainly was conveyed, at least at the implicit level, together with the more concrete results and

techniques explicitly taught in the treatises to the numerous readers of Fibonacci over the next centuries.

6.4. Jordanus Nemorarius

Jordanus Nemorarius is another highly interesting figure in Europe medieval mathematics and mechanics. Little is known of his life with certainty, but most likely he lived in the early 13th century. Since Campanus mentions him in his version of the *Elements*, Nemorarius surely lived before 1260. At the same time, from the contents of his treatises, it is clear that these were written after the various 12th century translations of the *Elements*. From a variety of scientific topics on which he wrote original treatises, his two most important arithmetical texts are *De elementis arismetice artis* and *De numeris datis*. Some of the results in *De elementis* are applied in *De numeris datis*, which indicates that the former work was composed before the latter one (Busard 1992, 123). It is also of interest to mention that there were failed attempts to produce printed versions of these two works by both Regiomontanus (1436-1476) and Francesco Maurolico (1494-1575). Finally, only the *Arithmetica* (as *De elementis* came to be known) appeared in two printed editions of 1496 and 1514 by the French humanist Jacques Lefèvre d'Étaples (1455-1536), also known as Stapulensis (Lefèvre d'Étaples 1496). In the early 16th century this book continued to be used as a textbook in many European universities (Busard 1991, 7-11). Likewise, even though *De numeris Datis* was never printed, a large amount of extant copies, dating from the 13th and up to the 16th centuries and found all around Europe, testify to a continued interest among mathematical audiences (Hughes 1981, 20-21). Still, it seems that the influence of Jordanus on his contemporaries was relatively limited, possibly because the *mathematical content* of this work was deeper than, and deviated

in style from, the more didactical and metamathematically-oriented texts associated with the Adelard-Robert tradition (Høyrup 1988, 341-343). Campanus de Novara, however, did read Jordanus and he incorporated many of his ideas into his version of the *Elements*, as we shall see right below, and in this way Jordanus' ideas could indirectly be of great influence for the processes discussed here.

Our focus here is Jordanus' *Arithmetica*, a treatise that embodies an attempt to provide a comprehensive, and indeed pioneering, theoretical foundation for arithmetic. Many details of the presentation seem to derive from a conscious striving to develop arithmetic without relying on geometrical concepts or results of any kind, while at the same time retaining the model and the standards of rigor set for geometry in Euclid's *Elements*. In doing so, it comprised a rather exhaustive overview of the body of theoretical Euclidean and Boethian arithmetic as was known at the time (though, curiously, the *Elements* are never explicitly referred to in the text). The treatise also betrays the influence of al-Khwārizmī, Abū Kāmil and Leonardo (Høyrup 1988, 310), and it is quite evident that al-Nayrīzī's text may have been among Nemorarius' main sources. In addition, in matters of overall style, if not of detail, the influence of *Liber Mahameleth* seems to surface at various places in the text. Yet, the *Arithmetica* was more than just a straightforward compilation of known results, and not only because it included many new propositions and new proofs of known propositions, but also because the style was highly original and because the synthesis thus produced presented a new overall image of a discipline that might have been systematically studied and further developed.³⁰

³⁰ (Høyrup 2010, 16) has argued that the potential impact of the *Arithmetica* materialized only to a very limited extent. Here I want to focus on the way in which, via its reading by Campanus, it did have an important influence in the specific issue of the increasingly arithmetic-algebraic conceptions of Book II.

Nemorarius' presentation starts from fourteen definitions, which somewhat overlap, but are not identical with, those appearing in Book VII of the *Elements*. He also included three original postulates (*petitiones*) and eight axioms (*communes animi conceptiones*), from which he derived more than four hundred propositions organized in ten books (the total number of propositions varying across the different extant manuscripts. See Busard 1991, 12). As in the Adelard II version of the *Elements*, in Nemorarius' text we often find a sketch of the argument that the reader is supposed to complete. Unlike Boethius, Jordanus did not illustrate his arithmetic arguments with numerical examples.³¹ And unlike Euclid, only some of the propositions are accompanied by diagrams where lines represent the numbers. This is a rather noteworthy point. In simpler proofs, where few different numbers are referred to and little confusion is likely to arise, Jordanus always preferred to refer to the various numbers involved in the argument using expressions such as “the first number”, “the largest of the two”, “the product of the whole by each part”, etc., and where possible he avoided calling them by letters. It is only when the argument became somewhat more involved that he introduced letters that served as names for the numbers referred to in the proofs. Only in such cases did he add letters to the diagram to indicate the additional, named numbers (as we shall see in an example below). And of course, whatever letters appeared in the proofs, Jordanus never operated on them as on abstract symbols. In this sense, *Arithmetica* displays noteworthy similarities to *Liber Mahameleth*. And, as in that book, propositions from Book II (namely II.1 to II.5), or variants thereof, play an important role here in creating the theoretical foundation on which Jordanus purported to build the entire edifice of arithmetical knowledge. This

³¹ The Stapulensis printed version of 1496 does include numerical examples. In this as well as in other respects it is interesting to compare the printed with the original Jordanus' version. We shall leave this comparison for a future opportunity.

is particularly the case concerning distributivity, for which Jordanus presented a detailed and original treatment in the preliminary section of the book, while drawing, wherever possible, only on the definitions, the postulates, and the axioms presented at the beginning. I discuss this important issue in detail in [LC2].

Here the focus is on Jordanus' rendering of II.5 in the *Arithmetica* (which I call here A-I.19), which offers many interesting vistas to his overall approach. It is important, first of all to explain the context where it appears as part of the preliminary section. After treating basic properties such as commutativity and distributivity in its various cases, Jordanus discusses Euclid's II.4 and several variants of it, namely, general rules for separating a given number into two arbitrary parts and then finding the relation between the square of the number and the partial products of its parts (this is discussed in detail in [LC2]). Then come two propositions that take this situation one step further, namely, separating a given number in two parts, but now *in two different ways*, and examining the relations between the possible partial products that arise thereby. The two propositions are formulated as follows (Busard 1991, 70):

A-I.19: If a number is divided into two equal and into two unequal parts, then the product of one of the equals by itself equals the product of one of the unequals by the remaining one together with the product of the difference by the difference.

A-I.20: If a number is divided into two parts in two ways whatsoever, the product of the greatest of the parts by the smallest together with the product of the difference of the [larger one] and one of the others by the difference of the same and the smaller equal the product of the two intermediate numbers.

The accompanying diagrams of the propositions are, respectively, as follows:

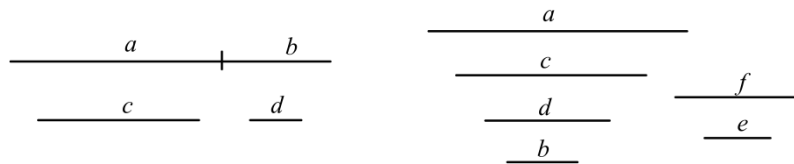

Figure 29

In the first case, we are told that a and b are the greater and lesser portions respectively, whereas c is “one of the two equal ones, both of which differ equally from b .” The difference is called d , and the proposition proves that “the product of a by b together with that of d by itself equals the product of c by itself”. In the second case, we are told that that a and b are the greater and lesser portions respectively, whereas c and d are, respectively, the greater intermediate and lesser intermediate ones. Here e is the difference between a and c , while f is the difference between a and d . The proposition thus proves that “the product of c by d equals the product of a by b together with that of e and f ”. Clearly proposition A-I.20 is a generalization of A-I.19, for the case where also the second separation is into unequal parts.³² This becomes more clearly apparent if we render them symbolically as follows:

$$\mathbf{A-I.19:} \text{ If } a + b = c + c, \text{ then } a \cdot b + (a-c) \cdot (a-c) = c \cdot c$$

$$\mathbf{A-I.20:} \text{ If } a + b = c + d, \text{ with } a > c > d > b, \text{ then } a \cdot b + (a-c) \cdot (a-d) = c \cdot d$$

³² It must be stressed, however, that Jordanus included in his treatise another proposition, A-X.3, which is in fact equivalent to A-I.19 and that embodies the so-called *Regula Nicomachi*: given three numbers in arithmetic progression, $a-b=b-c$, then we have $b^2 - a \cdot c = (a-b)^2$. Boethius has stated in his *Arithmetica* that this rule was discovered by Nicomachus (Busard 1991, 14). Jordanus’ very short proof of A-X.3 simply invokes A-I.19. This apparent repetition reflects, so it seems to me, Jordanus’ conscious view of A-I.19 as naturally belonging to the context of this preliminary type of results, where a given number is separated in two parts and the relations between the partial products, even if an equivalent form of it could appear in the context of a later book as well.

A closer look at the proofs brings to the fore some additional points that are of the foremost importance for a clearer understanding of Jordanus, and the various kinds of ideas involved in his treatise. For convenience have I rendered here the proofs schematically, without directly quoting them. This may give rise to some misrepresentation which I will nevertheless strive to avoid, among other things by translating word-by-word Jordanus' rhetoric, while even retaining his own symbols exactly the way they are used in the argument.

The steps of the proof of A-I.19 are the following (Square brackets enclose comments that do not appear in the original):

$$(k.1) \quad a + b = c + c; \quad d = c - b \quad [\text{or } c = d + b]$$

$$(k.2) \quad \text{By A-I.15 [i.e., Euclid II.4]: } c^2 = (d + b)^2 = d^2 + b^2 + 2 \cdot b \cdot d$$

$$(k.3) \quad \text{But } 2 \cdot d = a - b \quad [\text{or } b + 2 \cdot d = a \text{ (but this is not explicitly said!)}]$$

$$(k.4) \quad \text{Hence by A-I.14 [i.e., Euclid II.3]: } b^2 + 2 \cdot b \cdot d = b \cdot a$$

$$(k.5) \quad \text{Finally [from (k.2) and (k.4)]: } b \cdot a + d^2 = c^2 \quad \text{Q.E.D.}$$

In the proof of A-I.20 Jordanus invokes some additional results such as A-I.3, A-I.8 (commutativity of the product), and A-I.9 (distributivity). I do not comment here directly on these three propositions, as I say more about them in [LC2]. The steps of the proof of A-I.20 are the following:

$$(k.6) \quad \text{By A-I.3: since } a + b = c + d, \text{ then } a - c = d - b; \text{ and } a - d = c - b$$

$$(k.7) \quad \text{Hence, by A-I.9: } c \cdot d = c \cdot b + c \cdot e$$

$$(k.8) \quad \text{But by A-I.8: } c \cdot b + c \cdot e = b \cdot c + e \cdot c$$

$$(k.9) \quad \text{Again, by A-I.9: } e \cdot c = e \cdot b + e \cdot f$$

$$(k.10) \quad \text{But } e \cdot b = b \cdot e, \text{ and also, by A-I.9, } b \cdot c + b \cdot e = b \cdot a$$

$$(k.11) \quad \text{Finally, } c \cdot d = b \cdot a + e \cdot f \quad \text{Q.E.D.}$$

Let me now draw attention to the following, remarkable point: the crucial step in the proof of A-I.19 is (k. 3): “since twice d is the difference of a and b ”. Curiously, however, Nemorarius simply *states* this relation and provides *no explicit justification* for it. How is then this step justifiable? On first sight, one may be tempted to see this identity as following from (k.1), via some kind of symbol manipulation. This would involve something like the following putative steps:

$$(k'.1) \ a + b = 2 \cdot (d + b) \ \rightarrow \ a = b + 2 \cdot d \ \rightarrow \ 2 \cdot d = a - b$$

But notice that what is actually used in step (k.4) is the relation $b + 2 \cdot d = a$, which is the mid-step in this putative derivation and which I indicated in square brackets in (k.3). This would make the relation $2 \cdot d = a - b$ *irrelevant* for the derivation.

Why would Jordanus then write “twice d is the difference between b and a ” rather than “ a equals b and twice d ”, which is the rhetorical counterpart of the relation needed for step (k.4)? It seems, therefore, that we must look for the justification elsewhere, and as Jordanus remains silent, we can only speculate. My guess is that the sentence “twice d is the difference between b and a ” refers to a situation that can be derived from a *visual inspection* of the diagram. This can be seen by imaginarily extending in the following way the situation described in the original diagram of A-I.19:

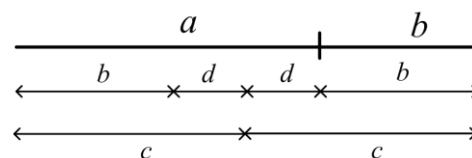

Figure 30

By directly inspecting a diagram like this one, it becomes clear that, indeed, “twice d is the difference between b and a ”, as stated by Jordanus.

We can find a rather similar situation in relation with the proof of A-I.20. Let me first stress how the concluding step (k.11) is actually reached. From (k.7) and (k.8), one obtains $c \cdot d = b \cdot c + e \cdot c$, and then, using (k.9) we get $c \cdot d = b \cdot c + e \cdot b + e \cdot f$. From here, using (k.10) we get the desired result $c \cdot d = b \cdot a + e \cdot f$. But notice that Jordanus invokes A-I.9 in three of the steps, whereas in fact, in order to apply this result in each of the steps some additional relations are required that are not explicitly mentioned in the text. Thus, for instance, how do we know in (k.7) that $d = b + e$, in order to conclude that $c \cdot d = c \cdot b + c \cdot e$? Or how do we know in (k.9) that $c = b + f$, in order to conclude that $e \cdot c = e \cdot b + e \cdot f$? Like in the case of A-I.19, we might, on first sight, suggest putative symbolic derivations that would help explain how Jordanus obtained the said relations, this time starting from (k.6). Thus, for instance, we might think of the following two:

$$(k'.2) \ a - c = e \text{ (by def.)}, \text{ but } a - c = d - b; \text{ hence } d - b = e \text{ and } d = b + e$$

$$(k'.3) \ a - d = f \text{ (by def.)}, \text{ but } a - d = c - b; \text{ hence } c - b = f \text{ and } c = b + f$$

But the problem with such an assumption is that not only does Jordanus remain silent about any derivation of this kind, but also that we do not find any other similar one, as far as I can see, in other parts in his treatise. Thus, I suggest that my conjecture for A-I.19 will also work in this case, if we imaginarily adapt, in the following way, the situation described in the original diagram of A-I.20 (and which is not much different from what I suggested above for A-I.19):

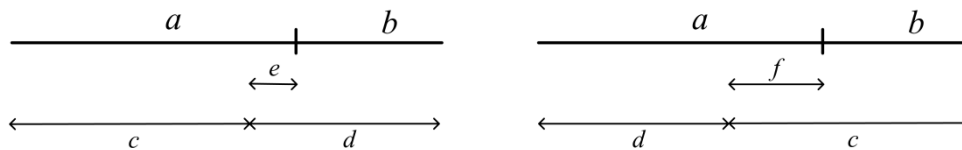

Figure 31

As above, by directly inspecting these two diagrams, it becomes clear that, indeed, $d = b + e$ and $c = b + f$, as implicitly used by Jordanus. Moreover, from the left-hand side, it also becomes clear that $a = c + e$, a relation which is implicitly used in (k.10).

These two proofs illustrate important characteristics of Jordanus' approach. On the one hand he goes to great pains in order to set clear the foundations of arithmetic and to abide by the standards set by Euclid in the case of geometry. On the other hand, he seems to have implicitly adopted some results that are necessary for completing the argument, without even commenting on them. I think that my conjecture above, about his possible use of diagrams as the source for these implicit assumptions, sheds some light on the situation. We already saw above several instances of implicit reliance on diagrams embedded in proofs. Thus was the case with Euclid's use of distributivity in the case of visible figures, or with some proofs of al-Khwārizmī and Abū Kāmil. But what is of special interest in the case of Jordanus is that, unlike those mentioned previously, he seems to have been relying on properties of diagrams of the *arithmetic* type, i.e., where the lines are not part of a geometric construction but rather, just indicative of the numbers involved.³³ I have also stressed this point by schematically rendering the proofs without reference to geometric constructions using $R(,)$ and $Sq()$ as with other authors above. But beyond the validity of my conjecture about Jordanus' reliance on diagrams it can be said with certainty that his arguments do not involve any kind of techniques that merit the adjective "algebraic". The proofs are not

³³ It is pertinent to refer the reader in this regard to (Puig 1994). This seldom-cited, but highly original article makes a remarkable connection between the arithmetic results presented in Jordanus' *De numeris Datis* and the diagrammatic aspects underlying the arguments of the proofs. I discuss this in some detail in [LC2].

based on abstract manipulation of symbols. They do not even involve following rules of *al-jabr* and *al-muqābala*, as Fibonacci did in his proofs mentioned above. And yet at the same time, all the preliminary section of his treatise is devoted to developing general rules of arithmetic that can be applied in changing situations. This is indeed what makes the book interesting as part of our account here, since it shows the extent to which a foundation of arithmetic, and an examination of the properties of the basic rules of calculating with numbers could be pursued without thereby moving into the territory of algebra. Specifically for II.5, it is interesting how Jordanus has moved it into a completely different realm from where it was originally conceived, and it was placed, in a truly natural way, within the framework of a rather thorough exploration of general, foundational rules of arithmetic. It is no wonder, then, that anyone that was exposed to this kind of treatment of II.5 could read this proposition, as part of Book II, as being about arithmetic (and in later periods even as being about rules of algebra). Some of this is already apparent in Campanus de Novara as we shall now see.

6.5. Campanus

I want to consider now the thirteenth-century Latin version of Euclid's *Elements* due to Campanus of Novara (c. 1220–1296), completed sometime between 1255 and 1259. As already said, this is the text that dominated European mathematics until the sixteenth century, and more than one hundred manuscripts of it have survived (Folkerts 1989, 38-43). Like other earlier translators and commentators discussed above, in preparing his text Campanus was also guided by clearly defined didactic considerations. He made considerable efforts to present Euclid's text as self-contained as possible, and free from obscure or debatable points such as found in Robert's text

(Busard 2005, 32). Indeed, Campanus repeated many of Robert's enunciations, but at the same time many of his proofs were original. More importantly, he also added significant amounts of material taken from sources such as al-Nayrīzī's commentary and Jordanus' *Arithmetica*. This is particularly remarkable in the case of Book IX, where Campanus incorporated into the original Euclidean text thirteen additions and comments comprising arithmetic versions of propositions from Book II. This is one of the main aspects that marks a clear difference between Campanus' version of the *Elements* and those that preceded it. Clearly all of this is highly relevant for our discussion here.

These additions are an interesting manifestation of the broader issue of Campanus' attitude towards the relationship between arithmetic and geometry. This relationship, in turn, is related to a more general medieval concern with the existence of parallel concepts and propositions in the *Elements* for handling separately magnitudes and numbers. In earlier versions of the Adelard-Robert tradition this concern was suggested in several places (Murdoch 1968, 88-89). In Campanus it becomes more explicit and central, and his additions and comments reflect an active interest in trying to come to terms in original ways with this concern.

Thus for instance, in his comment to VII.12 (which corresponds to Euclid's VII.11), Campanus asked why Euclid proved the more particular case of proportions with numbers in Book VII, if the general case for magnitudes had already been proved in Book V. The reason he gave for this is that the "*propria principia*" of the two books are different and, hence, corresponding propositions should be proved separately, and based on those principles alone in each case. In particular, he stressed, as the principles of Book VII relate to numbers, they are closer to the intellect and hence are more easily comprehensible than those treated in Book V, affected as the latter are by

the wickedness of the incommensurable quantities (“*propter malitiam quantitatum incommunicatum*”) (Busard 2005, 240; Rommevaux 1999, 89-92).³⁴

Against this background, let us consider more specifically the way in which Campanus presented the ideas of Book II. In the first place, I note that in Book II itself Campanus generally followed Euclid’s original approach, and thus remained within a completely geometric context. For propositions II.2-II.4, moreover, Campanus also presented alternative proofs along the lines of Heron’s approach (which he probably learnt from al-Nayrīzī’s commentary). The most interesting sentence in the entire Book II, however, appears at the end of the proof of II.10. Clearly intended to mark a separation between the first ten and the last four propositions of the book, Campanus stated that “this and all the previous propositions, are true for numbers as well as for lines” (Busard 2005, 103: “*hec autem et omnes premise veritatem habent in numeris sicut in lineis*”). This statement clearly allowed and justified using the first ten results of Book II in the context of the three arithmetic books of the *Elements*, as we shall see now.

Campanus’s treatment of Euclid’s three arithmetic books contains many modifications, additions, and comments to the original propositions.³⁵ In Book VII, for instance, he added numerical values to lines in the diagrams that accompany several of the propositions, apparently as a means to helping the reader figure out the situation more easily.³⁶ In addition, in some propositions unity is explicitly indicated

³⁴ See also Campanus’ comments to VII.6 (p. 236), which is compared with V.13 (i.e., Euclid V.12).

³⁵ All of these are very interesting in themselves, but discussing them would be beyond the scope of this article. See (Rommevaux 1999, 93-100).

³⁶ The only other place where we find such additions to the diagram is in the very last arithmetic proposition, IX.39.

in the figure either with its value 1 or with the word “*unitas*”. None of the numerical values, however, is used or mentioned in any way in the proofs of those propositions.

But as already stated, the most interesting additions appear as thirteen comments to a proposition in Book IX, namely IX.16, which Campanus took from Jordanus’

Arithmetica.³⁷ Eight of these comments are arithmetic formulations of propositions of Book II,³⁸ but they do not comprise numerical examples such as found in al-Nayrīzī’s text. Campanus provided proofs for all of them, and they are highly original and interesting. In those proofs that concern properties of distributivity (i.e., those related to II.2-II.4) we find further evidence of Campanus’ focus on the relationship between Books V and Books VII (I discuss this in some detail in [LC2]). Here I want to focus on the proof of II.5, whose argument substantially deviates from that of either Heron, or al-Nayrīzī or Jordanus.³⁹ What is of particular interest is that Campanus’ proof is fully arithmetic not only in the sense that it is evidently formulated as a property of numbers, but also in the sense that he uses an argument which is unlikely to have arisen in the kind of geometric context that Euclid originally devised for II.5. Let us see the details.

Campanus’ arithmetic version of II.5 appears as comment 7 of IX.16. The proof relies on comment 6, which is equivalent to Euclid’s II.4. The accompanying diagram is the following (p. 293):

³⁷ See (Busard 2005, 291), and also, proposition A-IV.19 of Jordanus in (Busard 1991, 103). Campanus’ proof is somewhat different from (and more detailed than) Jordanus’.

³⁸ These are comments 4-12. Comments 1-3 correspond to Jordanus’ A-I.9 to A-I.11, whereas comment 13 corresponds to Euclid’s V.11. See (Busard 2005, 33).

³⁹ The difference is directly noticeable by comparing steps (q.1)-(q.5) here below with steps (c.1)-(c.7) for Heron, with (p.1)-(p.5) for Jordanus, or with the algebraic interpretation that (Curtze 1899, 96) provides in a footnote for Al-Nayrīzī.

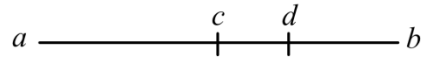

Figure 32

As usual, the segment ab is divided in equal parts at c and in unequal parts at d , and the argument of the proof reads as follows:

By the previous statement [i.e., II.4], the square of cb equals the square of cd and the square of db and twice the product of bd in cd . The products of bd by itself and by cb equal that by cb by the first comment here, and hence it equals that by ac . Hence, the product of bd by itself and twice that by cd equals that of bd by ad . And for the same reason the square of cb exceeds by the square of cd the product of bd by ad .

Schematically, the argument is the following:

$$(1.1) \text{ By II.4: } cb^2 = cd^2 + db^2 + 2 \cdot db \cdot cd$$

$$(1.2) \text{ By II.3: } bd^2 + bd \cdot cd = bd \cdot cb$$

$$(1.3) \text{ But } cb = ac; \text{ hence } bd^2 + bd \cdot cd = bd \cdot ac$$

$$(1.4) \text{ Hence: } bd^2 + 2 \cdot bd \cdot cd = bd \cdot ac + bd \cdot cd = bd \cdot ad$$

$$(1.5) \text{ Hence, by (1.1) and (1.4): } cb^2 = cd^2 + bd \cdot ad \quad \text{Q.E.D.}$$

The step that requires special attention here is (1.4). It is based on a tacit addition of $bd \cdot cd$ to both sides of an identity, followed by an application of II.3. This is the step that betrays the purely arithmetic context in which Campanus conceived the argument of his proof. Indeed, it would be highly unnatural, and certainly alien to Euclid's practice, to imagine a diagram that could graphically represent the passage from (1.3) to (1.4), that is, from $bd^2 + bd \cdot cd = bd \cdot ac$ to $bd^2 + 2 \cdot bd \cdot cd = bd \cdot ac + bd \cdot cd$. Because of the squares it is even difficult to imagine how this derivation could be represented in an arithmetic diagram of the kind that I conjectured above for

Jordanus' argument (and of course I have not rendered here the products as rectangle formation). Nor is it natural, I think, to interpret this kind of reasoning as embodying ideas derived from “*algebra almuchabala*”, as we have seen above for the case of Fibonacci. Rather, the passage from (1.3) to (1.4) is more naturally seen, I think, as arising from a direct application of the kind of general arithmetic rules that Jordanus worked out in his *Arithmetica*, and the kind of possible manipulations of numbers arising from it.⁴⁰

At this point we have arrived at one of the most significant milestones of this historical journey, given the decisive influence of Campanus in the process of transmission of the *Elements* to the printed world of the European renaissance and its subsequent dissemination. A typical reader of this version of the *Elements* would become acquainted with Campanus' discussion about the double presentation of the theory of proportions once for numbers and one for general magnitudes, and about the different nature of these two kinds of entities. Then, he would confront the results of Book II presented as comments to a result of Book IX, and bearing a purely arithmetic character in both their enunciations and the various steps of the proofs. And at the same time, of course, he would also read the same results in their fully geometric presentation, in the framework of Book II. With these two versions in front of him and with the increasing attention devoted to algebraic methods from the sixteenth

⁴⁰ Though I would not like to lay excessive stress on names, I feel it is improper to claim, as in (Busard 2005, 39), that “the algebraic method which Campanus used for proving Campanus IX.16 add. 4-12 agrees with the method which Anairitius used for proving II.2-II.10”. For one thing, I already indicated that both the “method” and the line of argumentation actually differ from that of Al-Nayrīzī. But also, using the term “algebra” in this context may be misleading since nothing here is manipulation of abstract symbols according to formal rules, not even in the manner intended in Islamic mathematics. Rather, Campanus simply operates on numbers (which are indicated with letters that serve as names) according to general, arithmetic rules.

century on, the reader might lay the stress on the essential differences between the two ways of presenting the same results as pertaining to two essential separate domains (one arithmetic and one geometric), but he might as well conflate both presentations as expressing two faces of one the same mathematical idea. Thus, for a historian trying to understand the ways in which the results of Book II were typically read and understood on the wake of the Campanus' version, the assumption that these results were conceived in *arithmetic* or *algebraic* terms, rather than as purely *geometric* ones, will not involve anymore the kind of anachronistic interpretation that was involved in making a similar judgment about the way in which the same results were conceived at the time of Euclid, and even by most other later authors whose works we have been investigating thus far. After Campanus in a definite manner, and perhaps also somewhat earlier in less clear-cut ways, the possibility of interpreting the results of Book II in terms of general rules for operating with numbers did not require the reader to incorporate into the text any mathematical idea not itself contained in the very text of the *Elements* that was available to him. At the same time, as we shall see now, not every reader of the *Elements*, posterior to Campanus, would necessarily adopt an entirely arithmetic reading of these results, and geometry was not quickly discarded as the source of certainty and legitimacy to be relied upon.

6.6. Gersonides

Levy Ben Gerson (1288-1344), also known as Gersonides, was the most prominent figure in the tradition of Jewish medieval sages with a keen interest in mathematics. If Bar Ḥiyya was the initiator of this tradition, Gersonides was certainly the first to contribute truly original mathematical ideas. He wrote treatises in various fields of interest, scientific as well as of Biblical exegesis. The most mathematically

interesting of them, dating from 1321, is *Sefer Maaseh Hoshev* (ספר מעשה חושב), a title that can be translated as “The Work of the Calculator”. Gersonides also wrote a commentary on Books I-IV of the *Elements* and a separate treatise on geometry, from which one may perhaps infer the extent and sources of his knowledge. Thus, as Tony Lévy has carefully documented (Lévy 1992, 87-92), there are some similarities between Gersonides’ text and some of the ideas found in al-Nayrīzī’s commentary. Gersonides may have been acquainted with the latter either in its Arabic original or in Gerard of Cremona’s Latin translation, or perhaps also via the Campanus edition. Still, other extant manuscripts raise the possibility of alternative sources and ways of transmission of Euclid’s texts to Jewish mathematicians. In his commentary on the *Elements*, Gersonides dealt with purely geometric questions such as a possible proof of the fifth postulate. Of Book II, he only discussed Proposition II.13. However, arithmetic versions of propositions from Book II do appear in *Maaseh Hoshev* and they are of interest for us here.

Maaseh Hoshev is a book on arithmetic and combinatorics in two parts.⁴¹ The Hebrew wording of the title embodies a thoughtful word play which opposes two terms, one stressing the “practical” aspect of the treatise (מעשה), the other stressing the “theoretical” one (חושב). Gersonides explained in the introduction that the purpose of his treatise was not just to teach the practical rules for solving arithmetic problems, but also the theory underlying those rules, since mastery of the former necessitates a full understanding of the latter. Gersonides also suggested that the prospective reader of his book should first master the contents of the three arithmetic books of the

⁴¹ Here I refer to the text as it appears in (Lange 1909), which is where the Hebrew text first appeared in print in modern times, together with a German translation. See also (Simonsen 2000) for a description of the contents, for some important remarks concerning the existing manuscripts and versions, and for additional parts not appearing in the Lange edition.

Elements, since proofs for propositions in those books would not be repeated the text. But the image of arithmetic that Gersonides presented was much broader than what the *Elements* contained and some of the proofs in the text go well beyond Euclid. *Maaseh Hoshev*, for instance, discussed many additive properties of the natural numbers as well as combinatoric results. He also followed ingenious arguments that came very close to mathematical induction (Rabinovitch 1970).

Gersonides started by proving some elementary properties of addition and multiplication, in a manner that reminds us of the preliminary section of Jordanus' *Arithmetica* discussed above. This preliminary section comprises results on distributivity and associativity of the product, as well as on identities involving the squares of a number separated into two parts. But Gersonides was much less systematic or exhaustive than Jordanus in his treatment. He included propositions that would be needed for proving more complex propositions later on in the text, as well as some others that are not even used, but it is not easy to discern a clear criterion for this choice.

Arithmetic versions of the first six propositions of Euclid's Book II appear among these preliminary results. Propositions II.1-II.4 are proved by straightforward arithmetic argument, namely, by counting units in each case. (I say more on this in [LC2].) But when we read Gersonides' versions of II.5-II.6 (which are, respectively MH-I.8 and MH-I.5), we find a more interesting and complex picture. Let us start by looking at Gersonides' text for MH-I.8, which reads as follows:⁴²

The area obtained by multiplying half of a given number by itself equals the area obtained by multiplying a part of that number by the remainder together with the

⁴² This is the version appearing in (Lange 1909, 5). It is remarkable that the proposition was not included in the second edition. See (Simonsen 2000, 297).

square of the difference between the part and half of the given number. Therefore let AB be the given number and let it be halved at point C , and divided at some other point D . I say that the square on the number AC equals the area obtained by multiplying the number AD by DB together with the square on CD .

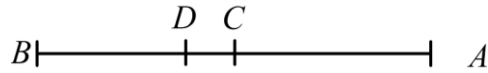
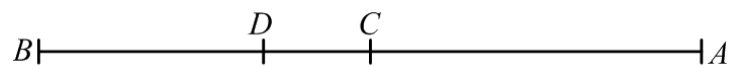

Figure 33

Proof: the square on AC equals the area of AC on CD together with the area of AC on DB , but the area of AD on DB equals the area of AC on DB together with the area of CD on DB . If we subtract the area of AC on DB which is common to them, then what remains from square AC equals the area of AC on CD , which equals the area of CB on CD , whereas what remains from the area AD on DB is the area CD on DB . But the excess of the area CB on CD over the area CD on DB equals the square on CD . Therefore, the square on AC equals the area of AD on DB together with the square on CD , and this is what we wanted.

Like Heron, also Gersonides bases the proof on using the elementary distributivity results of Book II in order to decompose, transform, and then compose again the basic figures obtained. He may have learnt this approach from al-Nayrīzī. But besides this basic similarity, his argument evidently takes a longer and rather less transparent path. This argument is more clearly understood when rendered symbolically, as follows:



$$(m.1) \quad \text{Sq}(AC) = R(AC, CD) + R(AC, DB) \quad [\text{by II.2}]$$

$$(m.2) \quad \text{On the other hand, } R(AD, DB) = R(AC, DB) + R(CD, DB)$$

$$(m.3) \quad \text{Hence } \text{Sq}(AC) - R(AC, CD) = R(AC, DB) = R(AD, DB) - R(CD, DB)$$

- (m.4) But $AC = CB$ [and hence $R(AC, CD) = R(CB, CD)$]
 (m.5) Hence $Sq(AC) - R(CB, CD) = R(AC, DB) = R(AD, DB) - R(CD, DB)$
 (m.6) But $R(CB, CD) = R(BD, CD) + Sq(CD)$ [by II.1]
 [and therefore $Sq(AC) - R(BD, CD) - Sq(CD) = R(AD, DB) - R(CD, DB)$]
 (m.7) Hence $Sq(AC) = R(AD, DB) + Sq(CD)$, Q.E.D.

If we wanted now to visualize the argument in terms of a diagram we could start with steps (m.1)–(m.2) as follows:

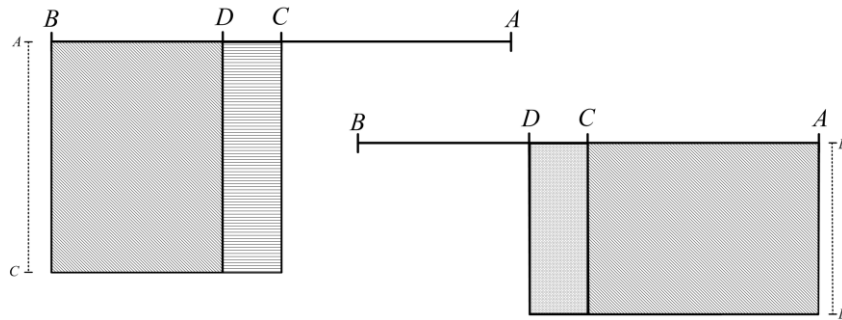

Figure 34

Step (m.3) introduces a kind of derivation that we had not seen so far, and in which the two above figures are compared by way of subtraction of areas, as follows:

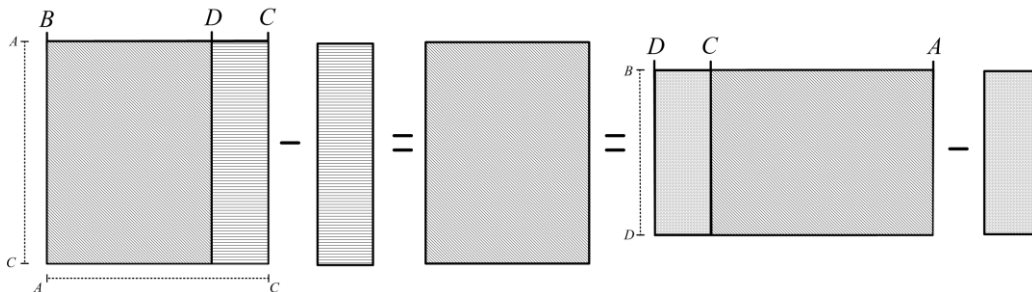

Figure 35

In step (m.4) the equality $CB=AC$ is invoked to obtain the identity in step (m.5):

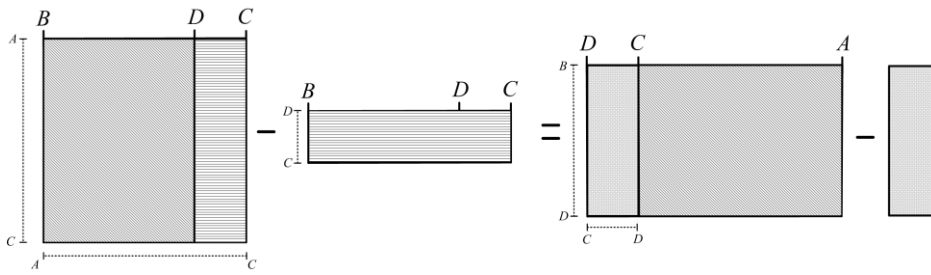

Figure 36

This step implies going even further than in step (m.3) since, unlike there, the areas that are subtracted here are not in the given figures to begin with. A further decomposition in (m.6) allows reaching in step (m.7) the identity to be established:

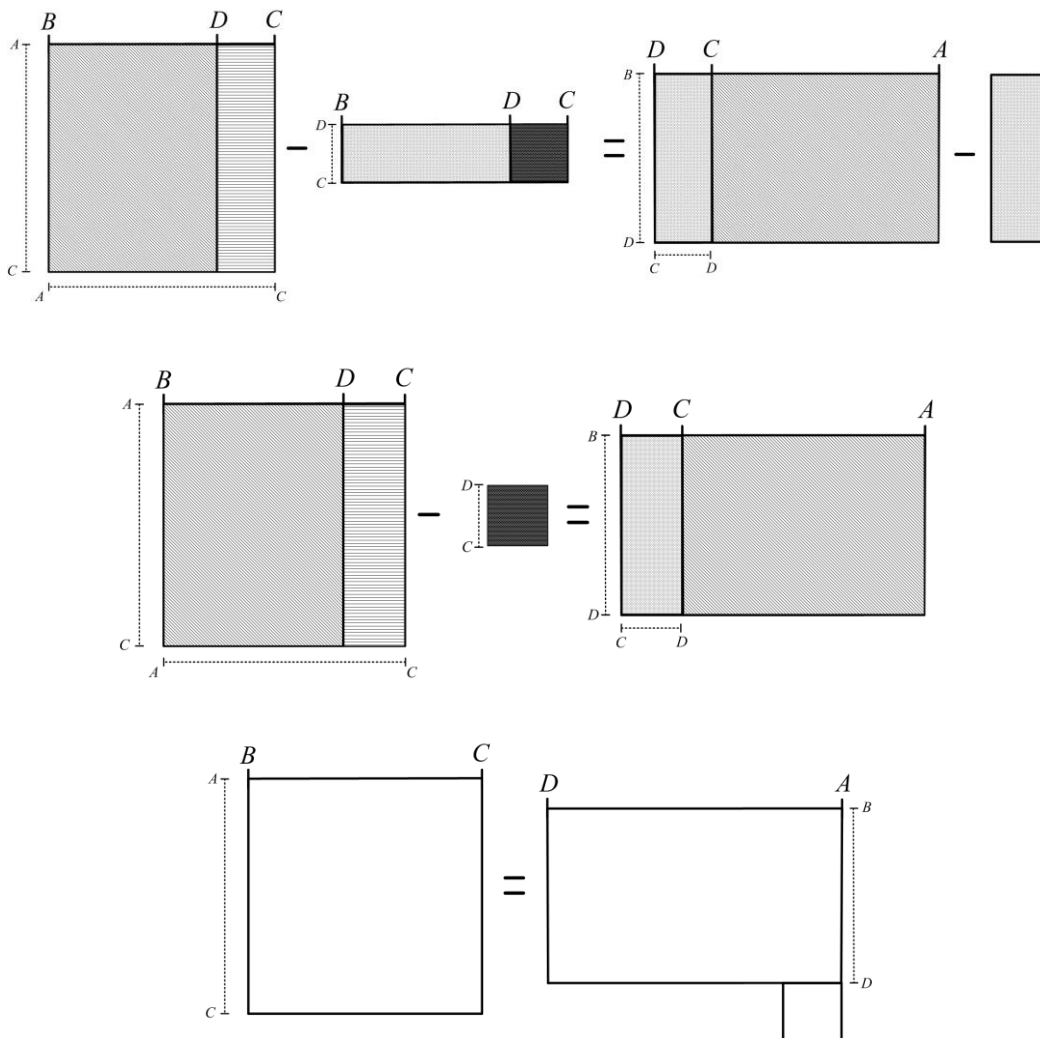

Figure 37

As with other cases above, also in this case one might raise the question whether this

geometric rendering of the text is the correct one, or if we should rather follow an arithmetic rendering. That is, we might ask if Gersonides conceived the argument while thinking about construction and manipulation of geometric figures as suggested in the diagrams above, or if, on the contrary, he thought in terms of general rules of multiplication and addition for numbers. The inclusions of steps such as (m.3) and (m.5) make this question of particular interest. I think that in this case there are good reasons to attribute Gersonides a more geometric kind of thinking, at least for this specific proposition. One reason for this is the language he used, in which a product is always dubbed “area” (שטח) or “square” (מרובע). This is of course inconclusive evidence, and we saw above some examples to the contrary, but it is at least indicative. Also, he did not choose here the arithmetic counting of units that he followed in other cases. But a more important consideration is that, while we have not seen other examples where areas are subtracted as part of a geometric argument, we have not seen either any example where this is done for numbers as part of an arithmetic one. And indeed, I find it unnatural to see how some of the crucial steps of the argument could have been conceived as part of a purely arithmetic derivation. Thus, for instance, it is not clear what could be the arithmetic idea behind a putative arithmetic rendering such as the following:

$$(m'.3) \quad AC^2 - AC \cdot CD = AC \cdot DB = AD \cdot DB - CD \cdot DB$$

Moreover, the geometric rendering also seems appropriate for the argument of MH-I.5, whose proof is based on repeated applications of distributivity properties, and which is accompanied by the following diagram:

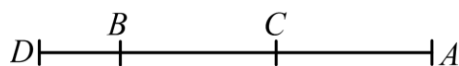

Figure 38

Here the “number AB ” (Gersonides’s term) is bisected at C and the “number BD ” is added. The proposition then states, as in II.6, that the area of AD by DB together with the square on CB equals the square on CD .

Gersonides’ proof is as follows:

$$(n.1) \quad R(AD, BD) = R(CD, DB) + R(AC, DB)$$

$$(n.2) \quad \text{But } R(AC, DB) = R(BC, DB)$$

$$(n.3) \quad [\text{Hence } R(AD, BD) = R(CD, DB) + R(BC, DB)]$$

$$(n.4) \quad \text{Hence by adding } \text{Sq}(CB),$$

$$R(AD, DB) + \text{Sq}(CB) = R(CD, DB) + R(BC, DB) + \text{Sq}(CB)$$

$$(n.5) \quad \text{But } \text{Sq}(CD) = R(CD, BD) + R(CD, CB)$$

$$(n.6) \quad \text{But } R(CD, CB) = R(CB, BD) + \text{Sq}(CB)$$

$$(n.7) \quad \text{Hence } \text{Sq}(CD) = R(CB, BD) + R(CB, BD) + \text{Sq}(CB)$$

$$(n.8) \quad \text{Hence } \text{Sq}(CD) = R(AD, BD) + \text{Sq}(CB), \quad \text{Q.E.D.}$$

In this case we find no subtractions as in the previous example, but here the steps are more straightforward and one can simply imagine them as being similar to those followed by Heron in his “operational” geometric proof.

Summarizing this section, then, one can say that Gersonides’ version of these two propositions is not easily classified as either geometric or arithmetic. On the one hand, it is clear that for him the two propositions are meant (like all other propositions in the book) to express properties of numbers, and not of geometric figures. On the other hand, while for other propositions in the book which were also arithmetic versions of propositions in Book II, he had provided arithmetic proofs, here he proceeded in ways that remind one of those of al-Khwārizmī and of his Islamic followers, namely, he provided a geometric justification for a result related to

numbers. It is evident that lacking a flexible language in which the various steps of the proof (as stated above) could be conceived and formulated in arithmetical, or proto-algebraic terms, an operational approach to geometric manipulation of areas, such as implicit in Heron's proof, offered a blueprint of a proof that could be more easily adapted to the arithmetic spirit of the book. Euclid's proof would have also worked here, of course, but it would have been much less akin to the arithmetic spirit of the proposition as conceived by Gersonides. In this sense, Gersonides' proofs do reflect a well-developed ability to manipulate abstract relations between numbers, albeit without having at hand a fully-developed symbolic language. Of course, the proofs discussed here are not among the most complex ones that Gersonides handles in the treatise, and yet I think that this conclusion applies broadly beyond the specific cases considered. In terms of historical development, at any rate, since *Maaseh Hoshev* had little or no visible influence on later mathematical developments in Europe, this highly original version of II.5 soon fell into oblivion.

6.7. Barlaam

The last text that I want to consider here is a highly original collection of results embodying arithmetic versions (not a commentary) of Euclid's propositions II.1-II.10, and commonly attributed to the 14th-century Basilian monk and scholar Barlaam de Seminara (ca. 1290-1348).⁴³ Barlaam is mentioned in passing in Heath's edition of the *Elements* (Heath 1956 [1908], Vol. 1, 74), as well as in some other places in the secondary literature, but it seems that there exists no serious historical research on him and on his startling Euclidean text.

⁴³ The full original Greek text appears in (Heiberg & Menge, 1883-1893, Vol. 5), as *Appendix Scholiorum* 4. I thank Michael Fried for help on translating parts of it.

In the text we find no preliminary explanations about the background, or about what exactly the author had in mind when composing it. Rather, the text itself opens with arithmetical definitions similar in spirit and in wording to those found in Book VII: multiples of numbers, plane numbers, parts of numbers. More generally, the wording of the propositions, and especially the accompanying diagrams, resemble those found in Books VII-IX: they are not geometric constructions needed to support the argument, but rather indications, with the help of various lines drawn one next to the other, of the various numbers mentioned in the proof. Still, in some places Barlaam's use of the lines appearing in the diagram deviates in important senses from standard usage. Let us see the details of his proof of II.5.

Barlaam's proof of this proposition relies on the use of II.1, and also, in an original way, of II.4. The accompanying diagram is as below (Heiberg & Menge, 1883–1893, Vol. 5, 730–732):

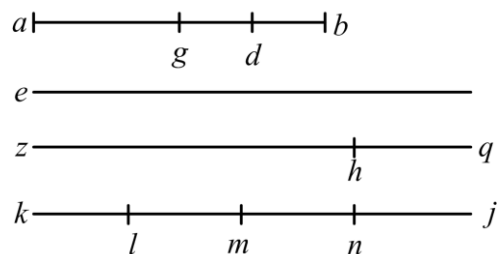

Figure 39

The standard line appearing in all diagrams of proofs of II.5 also appears here, with ab representing a number (Barlaam stresses that this is an *even* number), that is divided into two equal numbers ag, gb and into two unequal numbers ad, db . But the additional three lines are quite unusual. They are defined as follows:

- e represents “the square on gb ”
- zh is “the plane number from ad, db ”
- hq is “the square on gd ”

- kl is “the square on bd ”
- nj is “the square on dg ”
- lm, mn are each “the plane number obtained from bd, dg ”

According to the diagram (but not mentioned anywhere in the text) $kj = kl + lm + mn + nk$. Notice then, that by virtue of II.4 and by referring to the meaning attributed to each of the four segments, Barlaam implicitly takes kj to represent the square on $bd + dg$. This is nothing but the square on bg , which by definition is e . Also according to the diagram (and not mentioned anywhere in the text) $zq = zh + hq$. Thus, it is clear that the aim of the proof must be to show that also $zq = e$. The steps of the argument for reaching this conclusion can be schematically rendered as follows:

(o.1) By definition, $kl = bd \cdot bd$ and $lm = gd \cdot bd$. Hence $km = gb \cdot bd$

$$[\text{since } km = kl + lm \text{ and } gb = gd + db]$$

(o.2) But $gb = ga$, hence $km = ga \cdot bd$

(o.3) But by definition also, $mn = gd \cdot bd$. Hence by (o.1–o.2), $kn = ad \cdot bd$

$$[\text{since } kn = kl + mn \text{ and } ad = ag + dg]$$

(o.4) But also $zh = bd \cdot ad$. Hence [by (o.3)] $zh = kn$

(o.5) But $hq = nj$, since both were defined as $cd \cdot cd$. Hence $kj = zq$

$$[\text{since } kj = kn + nj \text{ and } zq = zh + hq]$$

(o.6) But $kj = e$ [by II.4 !!], so that [by (o.5)] $zq = e$

(o.7) But also $zq = ad \cdot db + dg^2$ [since in the diagram $zq = zh + hq$]

(o.8) Hence, $zq = ad \cdot db + dg^2$ and $zq = e$, so that $ad \cdot db + dg^2 = gb^2$ **Q.E.D.**

Barlaam’s proof presents another interesting example of an argument which is certainly based on operating with numbers and relies on general properties of these operations, but without thereby involving abstract manipulation of symbols. Nor does

there seem to be any kind of reliance on geometry. On the other hand, some of the information necessary for completing the proof derives from the diagram alone and is not explicitly mentioned in the text. Likewise, all the numbers involved are represented by straight lines, but some lines represent given numbers, while other represent numbers that arise from operations on the given numbers. The two kinds are treated differently. Worthy of special attention is the use of II.4 in step (o.6), since Barlaam tacitly completes the step by referring to a number for which only the diagram indicates the four factors that add up to it and that hence allow using the result previously proved, II.4. Even the wording attached to the use of II.4 is different, since it states that “since the number bg has been divided into two numbers gd, db , therefore the square on bg , namely e , is equal to the squares on bd, dg together with twice [the plane number from] bd, dg .”

Notice that, while the proof is stated in purely arithmetic terms and while some of its steps amount to counting the units in each of the terms involved, it still seems that in some crucial places the geometric background to the original propositions did underlie the line of argumentation. Thus, like Gersonides, Barlaam produced a version of II.5 which was intended to assimilate this result into the body of arithmetic and indeed, one might say, of *Euclidean* arithmetic. Their proofs, however, were different as was also the fate of their works. Contrary to Gersonides’ book, Barlaam’s text was well-known in the 16th century to authors of influential books, and some of them, such as Petrus Ramus (1515-1573) or Christopher Clavius (1538–1612), followed his formulations and his approach when handling II.5. Likewise, Sir Henry Billingsley (c. 1545-1606), who in 1570 published the first full English version of the *Elements* in 1570, explicitly relied on Barlaam’s text (Billingsley 1570, Folio 62). Explaining the details of Barlaam’s influence on these authors, however, is beyond the scope of the

present article. We can say, at any rate, that this rather remote text appears to have been instrumental in furthering the possibility of looking at II.5 from perspectives that departed from the original, purely-geometric one that underlies Euclid's conception.

7. Concluding Remarks

The first printed version of the *Elements* appeared in 1482 in Venice, based on Campanus' translation, and it is usually known as the Erhard Ratdolt edition. The first published translation into Latin from a Greek text of the *Elements* appeared in 1505, also in Venice. The Greek text had its origins in a slightly modified edition of Theon of Alexandria. By comparing this Greek text with Campanus' versions, its 16th-century translator into Latin, Bartolomeo Zamberti (c. 1474 – after 1539), excluded sections that in his opinion had been added by Theon (Rose 1975, 51 (note 56)). Zamberti was an influential humanist who played a somewhat paradoxical role in promoting certain conceptions about the *Elements* at the time. On the one hand, he supported a view, commonly associated with Proclus, that stressed the “marvelous” nature and unity of the *Elements*. According to this view the Euclidean text could not possibly be rearranged or improved by means of new demonstrations without serious damage to its perfection. On the other hand, Zamberti was also instrumental in popularizing a view according to which, the choice of definitions, postulates, and propositions in the *Elements* were Euclid's, whereas the demonstrations were Theon's. This alternative view opened the way to editions in which the Euclidean text was altered, summarized, divided, or published without the proofs (Goulding 2010, 152-159).

In 1516 Jacques Lefèvre d'Étaples (Jacobus Faber Stapulensis) attempted to reconcile the numerous discrepancies between existing translations of the *Elements* and came

up with a unified edition in which the Radtold's and the Zamberti's text appeared side-by-side. Eventually these two traditions, one stemming from Arabic sources (via Campanus) and one from Greek sources (via Zamberti), merged in the last third of the 16th century. In 1572 the edition of Federico Commandino (1509-1575), based on this new merging of traditions, appeared in print, marking an important milestone in the process of assimilation of the *Elements* as it came to be considered and understood in Europe.

The Euclidean traditions within the world of the printed text, which were inaugurated with the 1482 edition, and consolidated with the Commandino edition of 1572, differed in important senses from the medieval ones that I have been discussing along this article. This is certainly the case for the question of the changing relationship among geometric and arithmetic ideas. For one thing, a main starting point of these traditions was the Campanus' text, and the peculiar way in which Book II and the ideas related to it had been handled there. For another, new and vigorous trends of symbolic algebraic techniques began to attract increased attention and were incorporated into the text of the *Elements*. These new algebraic trends fitted in a relaxed manner into, and offered a natural continuation of, the kind of generalized arithmetic that Campanus, especially under the influence of Jordanus, had already made appear as the fundamental way to look at the results of Book II. Within the renaissance traditions of the *Elements*, then, Book II came to be understood in ways that went well beyond the purely geometric one that had informed Euclid's original conception. A detailed analysis of this topic is well beyond the scope of this article and I intend to pursue it at a future opportunity.

8. Acknowledgements

I want to pay my debt of gratitude to several friends and colleagues who read previous versions of this text, or parts of it, answered queries and sent me reading material, raised questions, suggested ideas and advanced critical views: Fabio Acerbi, Sonja Brentjes, Karine Chemla, Menso Folkerts, Jan Hogendijk, Jens Høyrup, Tony Levi, Anthony Lo Bello, Mark Moyon, Jeffrey Oaks, Sabine Rommevaux, Ken Saito, Shai Simonson, and Roy Wagner. Special thanks I owe to my friends Michael Fried and Miki Elazar for help and patience with translations of difficult passages from Latin and Greek, and to Veit Probst in Heidelberg, without whose kind mediation I would have had a much harder time in gathering all the material needed to complete this work. Last, but not least, hearty thanks go to Len Berggren, to whom I submitted this article for publication. His very detailed reading and thoughtful editorial suggestions helped me significantly improve (and somehow shorten) the entire text.

9. References

- Archibald, Raymond C. (1913), *Euclid's Book on Divisions of Figures with a Restoration Based on the Woepcke's Text and on the Practica Geometriae of Leonardo Pisano*, Cambridge: The University Press.
- Billingsley, Henry (1570), *The elements of geometrie of the most auncient philosopher Euclide of Megara. ...*, London.
- Boncompagni, Baldassare (1857), *Scritti di Leonardo Pisano matematico del secolo decimoterzo*. Vol. 1: *Il liber abbaci pubblicato secondo la lezione del codice Magliabechiano C. I, 2616*, Roma: Tipografia delle scienze matematiche e fisiche.
- Brentjes, Sonja (1994), “Textzeugen und Hypothesen zum arabischen Euklid in der Überlieferung von al-Ḥağğāğ b. Yūsuf b. Maṭar (zwischen 786 und 833)”, *Archive for History of Exact Sciences* 47, 53–92.
- (1996), “The relevance of non-primary sources for the recovery of the primary transmission of Euclid's *Elements* into Arabic”, in F. Jamil Ragep,,

Sally P. Ragep, and Steve Livesey (eds.), *Tradition, transmission, transformation : Proceedings of two conferences on Pre-Modern science held at the university of Oklahoma*, Leiden: Brill, pp. 201-225.

- (1997/8), “Additions to Book I in the Arabic Traditions of Euclid's Elements”, *Studies in History of Medicine & Science* 15 (1-2), 55-117.
- (2001a), “Observations on Hermann of Carinthia's Version of the Elements and its Relation to the Arabic Transmission”, *Science in Context* 14 (1-2), 39-84.
- (2001b), “Two comments on Euclid’s Elements? On the relation between the Arabic text attributed to al-Nayrızı and the Latin text ascribed to Anaritius”, *Centaurus* 43, 17-55.
- Busard, Hubertus L.L. (1968), *The Translation of the Elements of Euclid from the Arabic into Latin by Hermann of Carinthia (?)*. Edited with and Introduction, Leiden: Brill.
- (1983), *The First Latin Translation of Euclid's 'Elements', Commonly Ascribed to Adelard of Bath*, Toronto: Pontifical Institute of Medieval Studies.
- (1984), *The Latin Translation of the Arabic Version of Euclid's 'Elements', Commonly Ascribed to Gerard of Cremona*, Leiden: Brill.
- (1987), *The Medieval Latin Translation of Euclid's Elements made directly from the Greek*, Stuttgart: Steiner Verlag.
- (1991), *Jordanus de Nemore, De Elementis Arithmetice Artis. A Medieval Treatise on Number Theory* (2 Vols.), Stuttgart: Franz Steiner Verlag.
- (1992), “The Arithmetica of Jordanus Nemorarius”, in S S Demidov et al. (eds) *Amphora : Festschrift for Hans Wussing on the occasion of his 65th birthday*, Basel-Boston-Berlin: Birkhäuser Verlag, pp. 121-132.
- (1996a), *A Thirteenth-Century Adaptation of Robert of Chester's Version of Euclid's Elements*, Munchen: Institut für Geschichte der Naturwissenschaften.
- (1996b), “Einiges über die Handschrift Leiden 399,1 und die arabisch-lateinische Übersetzung von Gerhard von Cremona”, in J. Dauben, M. Folkerts, H. Wussing (eds.) *History of Mathematics: States of the Art*, San Diego: Academic Press, pp. 173–205.
- (2005), *Campanus of Novara and Euclid’s Elements* (2 vols.), Stuttgart: Franz Steiner Verlag.

- Busard, Hubertus L.L. and Menso Folkerts (1992), *Robert of Chester's (?) Redaction of Euclid's Elements, the so-called Adelard II Version* (2 vols.), Basel-Boston-Berlin: Birkhäuser Verlag.
- Clagett, Marshall (1978), *Archimedes in the Middle Ages. Volume iii: The Fate of the Medieval Archimedes, 1300 to 1565*, Philadelphia: American Philosophical Society.
- Corry, Leo (2004), *Modern Algebra and the Rise of Mathematical Structures* (2d. ed.), Basel-Boston-Berlin: Birkhäuser.
- (forthcoming), “The Law of Distributivity in the Medieval Traditions of Euclid’s *Elements*: Between Geometry and Arithmetic.” (Cited throughout as [LC2]).
- Corry, Leo and Norbert Schappacher (2010), “Zionist Internationalism through Number Theory: Edmund Landau at the Opening of the Hebrew University in 1925,” *Science in Context* 23 (4) , 427-471.
- Curtze, Maximilian (1899), *Anarithi in decem libros primos elementorum Euclidis commentarii ex interpretatione Gherardi Cremonensis in códice Cracoviense 569 servata*, Leipzig: Teubner (*Euclidis Opera Omnia*, I.L. Heiberg et H. Menge (eds.), supplementum).
- (1902), “Der Liber Embadorum des Abraham bar Chijja Savasorda in der Übersetzung des Plato von Tivoli,” *Abhandlungen zur Geschichte der mathematischen Wissenschaften*, 12, 1–183.
- Djebbar, Ahmed (2005), *L’algèbre arabe. Genèse d’un art*, Paris: Vuibert.
- Dold-Samplonius, Yvonne (1987), “Developments in the Solution to the Equation $cx^2 + bx = a$ from al-Khwarizmi to Fibonacci”, in David A. King and Georg Saliba (eds.), *From Deferent to Equant: A Volume of Studies in the History of Science in the Ancient and Medieval Near East in Honor of E.S. Kennedy*, New York: Annals of the New York Academy of Sciences, Vol. 500, pp. 71—87.
- Eastwood, Bruce S. (2007), *Ordering the Heavens. Roman Astronomy and Cosmology in the Carolingian Renaissance*, Leiden: Brill.
- Folkerts, Menso (1970), *Boethius “Geometrie II”: ein mathematisches Lehrbuch des Mittelalters*, Wiesbaden: Franz Steiner.
- (1981), “The Importance of the Pseudo-Boethian *Geometria* During the Middle Ages”, in M. Masi (ed.) *Boethius and the Liberal Arts: A Collection of Essays*, Berne, pp. 187-209 (Reprinted in Menso Folkerts (2003), *Essays on Early Medieval Mathematics: The Latin Tradition*, Aldershot: Ashgate.

----- (1989), *Euclid in Medieval Europe*, Winnipeg: The Benjamin Catalogue.

----- (2004), "Leonardo Fibonacci's knowledge of Euclid's Elements and of other mathematical texts", *Bollettino di Storia della Scienze Matematiche* 24, 93-114.

----- (2006), *The Development of Mathematics in Medieval Europe. The Arabs, Euclid, Regiomontanus*, Aldershot: Ashgate Publishing Limited.

Freudenthal, Hans (1977), "What is Algebra and What Has it Been in History", *Archive for History of Exact Sciences* 16 (3), 189-200.

Fried, Michael N. and Sabetai Unguru (2001), *Apollonius of Perga's Conica. Text, Context, Subtext*, Leiden: Brill.

Goldstein, Bernard (1965), "A Treatise on Number Theory from a Tenth Century Arabic Source", *Centaurus* 10, 124-160.

Grant, Edward (ed.) (1974), *A Source Book in Medieval Science*, Cambridge, MA: Harvard Univ Press.

----- (1983), Review of (Hughes 1981), *Historia Mathematica* 10, 125-129.

Grattan-Guinness, I., (1996), "Numbers, Magnitudes and Proportions in Euclid's *Elements*", *Historia Mathematica* 23, 355-375

Goulding, Robert (2010), *Defending Hypathia. Ramus, Saville, and the Renaissance Rediscovery of Mathematical History*, Dordrecht, Heidelberg, London, New York: Springer.

Guillaumin, Jean-Yves (2012), "Boethius' *De Institutione arithmetica* and its Influence on Posterity", in Noel H. Kaylor and Philip E. Phillips (eds.), *A Companion to Boethius in the Middle Ages*, Leiden: Brill, pp. 135-162.

Guttmann, Yehiel Michael HaCohen (1912-13), *Chibbur Ha-Meschicha WeHa-Tischboreth - Lehrbuch der Geometrie des Abraham bar Chija* (2 vols.), Berlin: Schriften des Vereins Mekize Nirdamim.

Heath, Thomas (1956) [1908], *The Thirteen Books of Euclid's Elements*, New York: Dover.

----- (1981) [1921], *History of Greek Mathematics* (2 vols.), New York: Dover.

Heiberg, Johan Ludvig and Menge, Heinrich, (1883-1893), *Euclidis opera omnia. Ediderunt et latine interpretati sunt I. L. Heiberg et H. Menge* (12 vols.), Leipzig: Teubner.

- Hogendijk, Jan P. (2005), “Al-Nayrīzī’s Influence in the West”. (Downloaded February 14, 2010, from <http://www.jphogendijk.nl/publ/naywest.pdf>)
- Høyrup, Jens (1986), “Al-Khwārizmī, Ibn Turk, and the Liber Mensurationum: on the Origins of Islamic Algebra”, *Erdem* 2 , 445–484.
- (1988), “Jordanus de Nemore, 13th Century Mathematical Innovator”, *Archive for History of Exact Science* 38, 307-363.
- (1998), “A New Art in Ancient Clothes. Itineraries Chosen between Scholasticism and Baroque in Order to Make Algebra Appear Legitimate, and Their Impact on the Substance of the Discipline”. *Physis*, n.s. 35, 11–50.
- (2001), “On a Collection of Geometrical Riddles and their Role in the Shaping of Four to Six ‘Algebras’”, *Science in Context* 14 (1-2), 85-131.
- (2010), “Hesitating progress: the slow development toward algebraic symbolization in abacus-and related manuscripts, c. 1300 to c. 1550”, in Albrecht Heeffer & Maarten Van Dyck (eds), *Philosophical Aspects of Symbolic Reasoning in Early Modern Mathematics* (Studies in Logic, 26), London: College Publications, pp. 3–56.
- Hughes, Barnabas (1981), *Jordanus de Nemore. De numeris datis. A Critical Edition and Translation*, Berkeley – Los Angeles – London: University of California Press.
- (2008), *Fibonacci’s De Practica Geometrie*, New York: Springer (Sources and Studies in the History of Mathematics and Physical Sciences).
- Kibre, Pearl (1984), “The Boethian *De Institutione Arithmetica* and the Quadrivium in the Thirteenth Century University Milieu at Paris”, in Michael Masi (ed.) *Boethius and the Liberal Arts: A Collection of Essays*, Bern/Frankfurt: Peter Lang, pp. 67-80.
- Klein, Jacob (1968) [1934–36], *Greek Mathematical Thought and the Origin of Algebra*, translated by Eva Brann, Cambridge, MA: MIT Press.
- Lange, Gerson (1909), *Sefer Maassei Chosheb. Die Praxis des Rechners. Ein hebräisch-arithmetisches Werk des Levi ben Gerschom aus dem Jahre 1321*, Frankfurt am Main: Louis Golde.
- Lefèvre d’Étaples, Jacques (1496), *Arithmetica decem libris demonstrata*, Paris: Johannes Higman and Wolfgang Hopyl.
- Levey, Martin (1966), *The Algebra of Abū Kāmil. Kitāb fī al-jābr wa'l-muqābala, in a Commentary by Mordecai Finzi* (Hebrew Text, Translation and Commentary

with Special Reference to the Arabic Text), Madison: University of Wisconsin Press.

Lévy, Tony (1992), “Gersonide, commentateur d'Euclide: Traduction annotée de ses gloses sur les *Elements*”, in Gad Freudenthal (ed.), *Studies on Gersonides: A Fourteenth-Century Jewish Philosopher-Scientist. Collection de Travaux de L'Académie Internationale d'Histoire des Sciences*, vol. 36, Leiden: Brill, pp. 83-148.

----- (1997a), “Les ‘Eléments’ d’Euclide en hébreu (XIIIe–XVIe siècles)”, in M. Aouad, A. Elamrani-Jamal, and A. Hasnaoui (eds.), *Perspectives arabes et médiévales sur la tradition scientifique et philosophique grecque*, Leuven: Peeters, pp. 79–94.

----- (1997b), “Une version hébraïque inédite des ‘Eléments’ d’Euclide,” in D. Jacquart (ed.), *Les voies de la science grecque*, Geneva: Droz, pp. 181–239.

----- (1997c), “The Establishment of the. Mathematical Bookshelf of the Medieval Hebrew Scholar: Translations and Translators”, *Science in Context* 10 (03), 431-451.

----- (2001), “Les débuts de la littérature mathématique hébraïque: la géométrie d’Abraham bar Ḥiyya (XIe-XIIe s.)”, *Micrologus* 9, 35-64.

Lo Bello, Anthony (2003a), *Gerard of Cremona's Translation of the Commentary of Al-Nayrīzī on Book I of Euclid's Elements of Geometry. With an Introductory Account of the Twenty-Two Early Extant Arabic Manuscripts of the Elements*, Leiden: Brill.

----- (2003b), *The Commentary of Albertus Magnus on Book I of Euclid's Elements of Geometry*, Leiden: Brill.

----- (2009), *The Commentary of al-Nayrīzī on Books II-IV of Euclid's Elements of Geometry. With a Translation of That Portion of Book I Missing from MS Leiden Or. 399.1, but Present in the Newly Discovered Qom Manuscript edited by Rüdiger Arnzen*, Leiden: Brill.

Luckey, Paul, 1941. “Tābit b. Qurra über den geometrischen Richtigkeitsnachweis der Auflösung der quadratischen Gleichungen”. *Sächsischen Akademie der Wissenschaften zu Leipzig. Mathematisch-physische Klasse. Berichte* 93, 93–114.

Millás-Villacrosa, José María (1931), *Abraam bar Hiia, Llibre de geometria. Hibbur hameixihà uehatixboret*, Barcelona: Editorial Alpha.

Moyon, Mark (2007), “La tradition algébrique arabe du traité d’Al-Khwārizmī au Moyen Âge latin et la place de la Géométrie”, in Evelyne Barbin and

Dominique B nard (eds.) *Histoire et enseignement des math matiques. Rigueurs, erreurs, raisonnements*, Lyon: INRP, pp. 289-318.

Mueller, Ian (1981), *Philosophy of Mathematics and Deductive Structure in Euclid's Elements*, Cambridge, MA, MIT Press.

Murdoch, John (1966), "Euclides Graeco-Latinus: A Hitherto Unknown Medieval Latin Translation of the *Elements* Made Directly from the Greek", *Harvard Studies in Classical Philology* 71, 249-302.

----- (1968), "The Medieval Euclid: Salient Aspects of the Translations of the *Elements* by Adelard of Bath and Campanus of Novara", *Revue de synth se* (ser.II) 1, 67-94.

----- (1971), "Euclid: Transmission of the *Elements*," *Dictionary of Scientific Biography* Vol. 4, 437-459.

----- (2003), "Transmission into Use: The Evidence of Marginalia in the Medieval Euclides Latinus", *Revue d'histoire des sciences* (2), 369-382.

Neal, Katherine (2002), *From Discrete to Continuous: The Broadening of the Number Concepts in Early Modern England*, Dordrecht: Kluwer.

Netz, Reviel (1999), *The Shaping of Deduction in Greek Mathematics: A Study in Cognitive History*, Cambridge: Cambridge University Press.

Oaks, Jeffrey (2001), "Geometry and Proof in Ab  K mil's Algebra", in *Actes du 10 me Colloque Maghr bim sur l'Histoire des Math matiques Arabes*, Tunis: L'Association Tunisienne des Sciences Math matiques, pp. 234-256.

----- (2011), "Al-Khayy m's Scientific Revision of Algebra", *Suhayl : Journal for the History of the Exact and Natural Sciences in Islamic Civilisation* 10, 47-75.

Pacioli, Luca (1523) [1494], *Summa de Arithmetica Geometria Proportioni et Proportionalit * (2d. ed.), Toscolano: Paganino de Paganini.

Puig, Luis (1994), "El De Numeris Datis de Jordanus Nemorarius como sistema matem tico de signos", *Mathesis* 10, 47-94.

Rabinovitch, Nahum L. (1970), "Rabbi Levi ben Gershon and the origins of mathematical induction", *Archive for History of Exact Sciences* 6, 237-248.

Rommevaux, Sabine (1999), "La proportionnalit  num rique dans le Livre VII des  l ments de Campanus", *Revue d'histoire des math matiques* 5, 83-126.

- (2008), “The transmission of the Elements to the Latin West : three case studies”, in Eleanor Robson et Jackie Stedall (eds.), *The Oxford Handbook of the History of Mathematics*, Oxford: Oxford University Press, pp. 687-706.
- Rommevaux, Sabine, Ahmed Djebbar and Bernard Vitrac (2001), “Remarques sur l’Histoire du Texte des Eléments d’Euclide”, *Archive for History of Exact Sciences* 55, 221-295.
- Rose, Paul Lawrence (1975), *The Italian Renaissance of Mathematics. Studies on Humanists and Mathematicians from Petrarch to Galileo*, Genève: Librairie Droz.
- Rosen, Frederic (1831), *The Algebra of Mohammed ben Musa*, London.
- Saito, Ken (2004) [1985], “Book II of Euclid's Elements in the Light of the Theory of Conic Sections”, *Historia Scientiarum* 28, 31-60 (Reprinted in Jean Christianidis (ed.), *Classics in the History of Greek Mathematics*, Boston Studies in the Philosophy of Science, Vol. 240, Dordrecht-Boston: Kluwer, pp. 139-168).
- Saito, Ken and Nathan Sidoli (2012), “Diagrams and arguments in ancient Greek mathematics: lessons drawn from comparisons of the manuscript diagrams with those of modern critical editions”, in Karine Chemla (ed.) *The History of Mathematical Proof in Ancient Traditions*, Cambridge: Cambridge University Press, pp. 135-162.
- Sarfatti, Gad B. (1968), *Mathematical Terminology in Hebrew Scientific Literature of the Middle Ages* (מונחי מתמטיקה בספרות המדעית העברית של ימי הביניים), Jerusalem: Magnes Press.
- Sesiano, Jacques (1987), “Survivance médiévale en Hispanie d'un problème né en Mésopotamie”, *Centaurus* 30 (1), 18-61.
- (1993), “La version latine médiévale de l'Algèbre d'Abû Kâmil”, in Menso Folkerts and Jan P. Hogendijk, *Vestigia Mathematica. Studies in Medieval and Early Modern Mathematics in Honour of H. L. L. Busard*, Amsterdam et Atlanta: Rodopi, pp. 315-452.
- Sigler, Laurence, E. (2002), *Fibonacci's Liber Abaci. A Translation into Modern English of Leonardo Pisano's Book of Calculation*, New York: Springer (Sources and Studies in the History of Mathematics and Physical Sciences).
- Simi, Annalisa (2004), “L’eredità della *Practica geometriae* di Leonardo Pisano nella geometria del basso Medioevo e del primo Rinascimento”, *Bollettino di Storia della Scienze Matematiche* 24, 9-43.

- Simonson, Shai (2000), “The Missing Problems of Gersonides – A Critical Edition”, *Historia Mathematica* 27, (3): 243-302 & (4): 384-431.
- Simson, Robert (1804), *The Elements of Euclid, viz. The first Six Books, Together with the Eleventh and Twelfth also the Book of Euclid's Data*, London: F. Wingrave.
- Tummers, Paul M.J.E. (1980), “The Commentary of Albert on Euclid’s Elements of Geometry”, in J. A. Weisheipl (ed.), *Albertus Magnus and the Sciences: Commemorative Essays*, Toronto: Pontifical Institute of Mediaeval Studies, pp. 479-498.
- (1994), *Anaritius' Commentary on Euclid. The Latin translation I-IV* (Artistarium Supplementa IX), Nijmegen: Ingenium Publishers.
- Unguru, Sabetai (1975), “On the Need to Rewrite the History of Greek Mathematics”, *Archive for History of Exact Sciences* 15, 67-114.
- Unguru, Sabetai and David Rowe (1981-82), “Does the Quadratic Equation have Greek Roots?”, *Libertas Mathematica* 1, 1-49; 2, 1-62.
- Vitrac, Bernard (2003), “Les scholies grecques aux Éléments d'Euclide”, *Revue d'histoire des sciences* 56, 275-292.
- (2004), “A propos des démonstrations alternatives et autres substitutions de preuves dans les Éléments d'Euclide”, *Archive for History of Exact Sciences* 59, 1-44.
- (2011), “Faut-il réhabiliter Héron d'Alexandrie ?”, Montpellier : France. (Downloaded May 02, 2012, from <http://hal-paris1.archives-ouvertes.fr/hal-00454027>.)
- Vitrac, Bernard and Maurice Caveing (1990), *Euclide d'Alexandrie. Les Éléments. Traduit du texte de Heiberg* (Vol. I. Introduction générale par Maurice Caveing. Livres I-IV: géométrie plane. Traduction et commentaires par Bernard Vitrac), Paris: Presses Universitaires de France.
- Vlasschaert, Anne-Marie (2010), *Le Liber Mahameleth : édition critique et commentaries*, Stuttgart: Franz Steiner Verlag.
- Waerden, Bartel L. van der (1976), “Defense of a 'Shocking' Point of View”, *Archive for History of Exact Sciences* 15, 199-210.
- Weil. André, (1978), “Who Betrayed Euclid?”, *Archive for History of Exact Sciences* 19, 91-94.

Weinberg, Josef (1935), *Die Algebra des Abū Kāmil Šoğā'ben Aslam*, München:
Druck der Salesianischen Offizin.